

# PATHFINDERLED.™

ADVANCED MOTORCYCLE LIGHTING

## INSTALLATION INSTRUCTIONS GL1800/F6B RECTANGULAR LED FOG LIGHT KIT



PART NO. GL18RFL

**STOP! IF YOU NEED SERVICE OR SUPPORT – DO NOT RETURN PRODUCT TO STORE**  
FOR SERVICE / SUPPORT CONTACT: [Service@SoCalMotoGear.com](mailto:Service@SoCalMotoGear.com)



We recommend that you watch the Installation Video: [1800/F6B] [www.SoCalMotoGear.com/gl18rflvideo](http://www.SoCalMotoGear.com/gl18rflvideo)  
[F6C/VALKYRIE] [www.SoCalMotoGear.com/f6cvideo](http://www.SoCalMotoGear.com/f6cvideo)

**VALKYRIE F6C OWNERS ONLY: SEE PAGE 5 FOR IMPORTANT INFORMATION PERTAINING TO YOUR MOTORCYCLE**

This product is intended for aftermarket use and have been fit checked on stock, non-modified OEM motorcycles. As with any aftermarket products, there may be some slight modifications required. This product is recommended to be installed professionally. *Non U.S. Motorcycles: This kit may not be Plug and Play on non U. S. spec motorcycles. International models (outside of United States of America) may require different installation steps regarding wiring.*

### PARTS LIST

Label	Description	Qty
A	LED Fog Light (Rectangular)	2
B	Right Mounting Bracket	1
C	Left Mounting Bracket	1
D	4 mm Spacer	3
E	20 mm Spacer	1
F	16 mm Spacer	2
G	Small Flange Insert	4
H	M5 x 18 mm Screw	4
I	Large Flange Insert	6
J	Large Rubber Grommet (w/ bracket)	6
K	Flat Washer - large	6
L	M6 Flange Bolt - long	3
M	M6 Flange Bolt - short	3
N	On/Off Switch	1
O	Zip Tie	3
P	Fog Light Wire Harness	1
Q	Spring	1
--	M5 x 38 mm Screw (not shown)	2
--	2 mm Spacer (not shown)	6
--	Jumper Plug (not shown)	2
--	Posi Tap Wire Connectors (not shown)	4

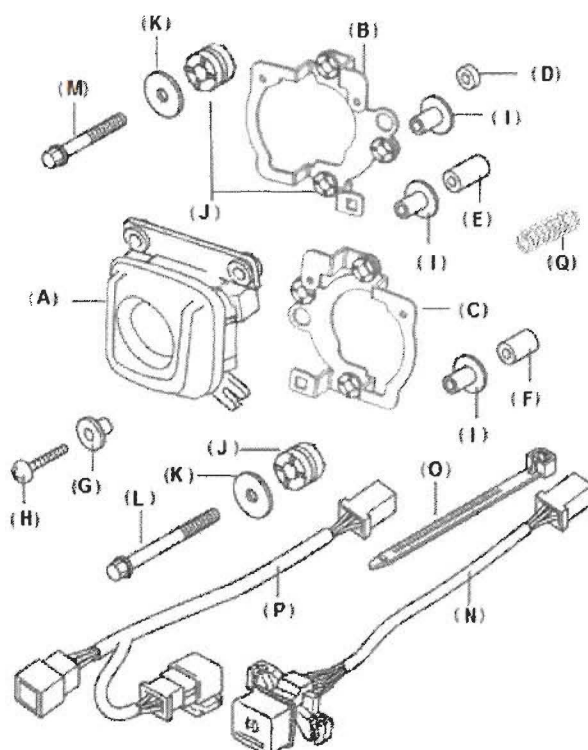

**\*\*PLEASE READ INSTALLATION GUIDE CAREFULLY BEFORE STARTING INSTALLATION\*\***

*Please obey all state and local laws regarding the use of additional lighting.*

### IMPORTANT

The memory settings of the suspension system, trip meter, clock, and radio will be lost when disconnecting the negative battery cable. Reset your settings after reconnecting the battery. Upon completion of the installation, be sure to check that all components are working properly before riding.

**NOTE:** Due to different lighting conditions, U-shaped LED running lights are only used to enhance the look of the bike and should not be solely relied on for driving conditions. When fog lights are in use, the brightness of the U-shaped LEDs will be dimmed.

## INSTALLATION STEPS:

**STEP 1.** Place motorcycle on center stand.

**STEP 2.** Disconnect the negative cable from the battery.

**STEP 3.** Remove the lower front cowl following your service manual instructions.  
**Secure all wiring away from any moving parts or extreme heat with zip ties.**

**NOTE:** Right side of bike is the throttle side, left side is the clutch side.

### STEP 4.

Using cutting pliers or cutter, remove the marked areas from the front lower cowl and smooth / flat the edges with file.

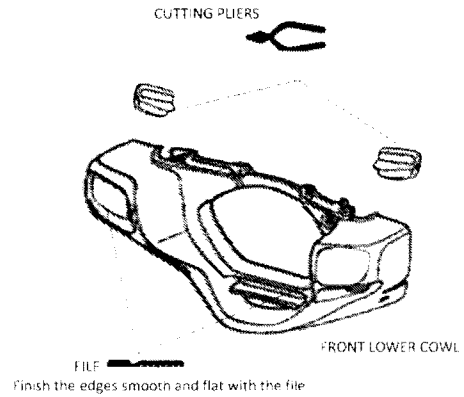

### STEP 5.

Right and Left **inner** mounting brackets (Markings "R" and "L" can be found on the back of the brackets).

**NOTE:** Illustration shows the three large grommets out of the holes, however, the **Grommets are already affixed for your convenience.**

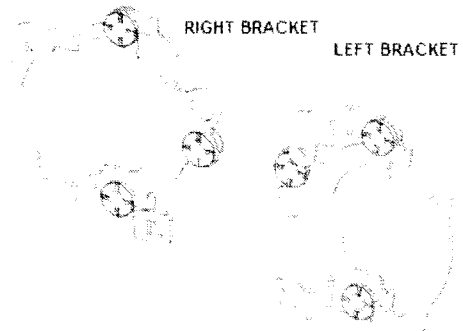

### STEP 6.

Separate fog light from outer bracket by removing the two small screws holding fog light to outer bracket.

### STEP 7.

Place spring over M5 x 38mm screw and washer. Screw into square black plastic nut in each mounting bracket.

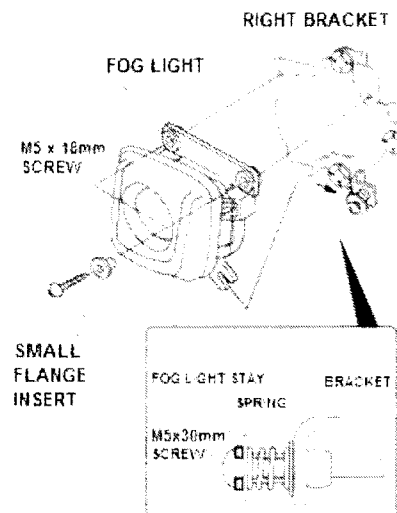

**STEP 8.** Remove the parts as shown.

LEFT

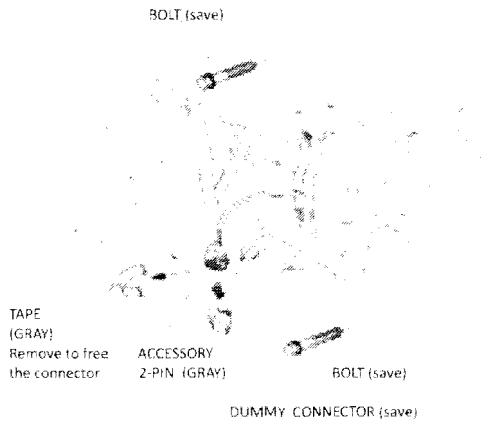

RIGHT

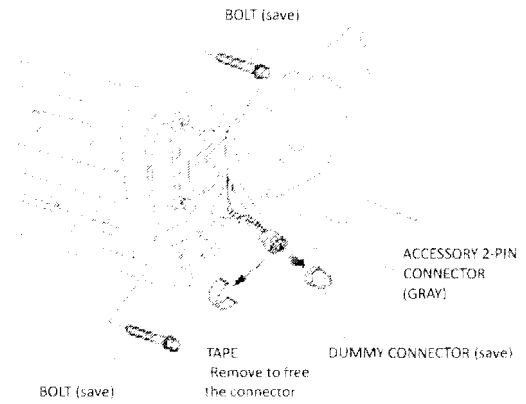

**STEP 9.**

Install Right **inside bracket** on bike as shown.

Using:

- 3 - "short" M6 flange bolts
- 3 - large flange inserts
- 3 - flat washers (large)
- 1 - 4 mm spacer, and plastic trim piece

RIGHT

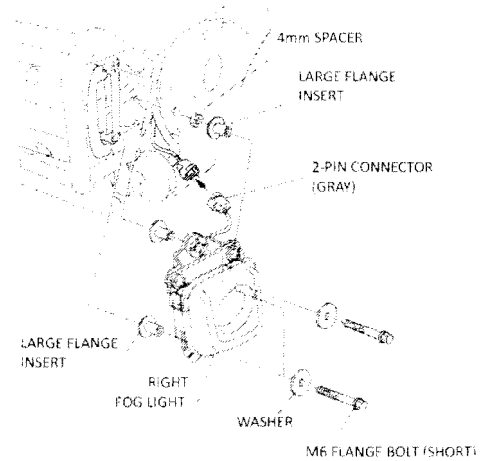

**STEP 10.**

- Install Right outer bracket onto inside bracket using two M5 x 18mm screws, two small flange inserts.
- Insert adjustment bracket between the screw head and washer as shown in step 8.

**STEP 11.**

- Thread the 2 pin connector through bracket and plug into the existing fog light connector.
- Thread the two wire cable through the bracket this wire will be fished up to the area of the mirror and connected to the turn signal wiring.
- Install the right side fog light into outer bracket using the two small screws (one each side of light).

**STEP 12.** Install the left inner bracket using three "long" M6 flange bolts, three flat washers (large), two 16 mm spacers on top and bottom bolts, and one 20 mm spacer for inside bolt.

**STEP 13.**

- Install the Left outer bracket onto the inner bracket using two M5 X 18mm screws, two small flange inserts.
- Insert adjustment bracket between the screw head and washer as shown in step 8.

**STEP 14.**

**A.** Install the left fog light into outer bracket using the two small screws (one each side of light).

**B.** Thread the two pin connector through the bracket and plug into the existing connector.

**C.** Run the two wire cable through the bracket. This wire will be fished up to the area of the mirror and connected to the turn signal harness.

**D.** Install the left fog light into outer bracket using the two small screws (one each side of light).

LEFT

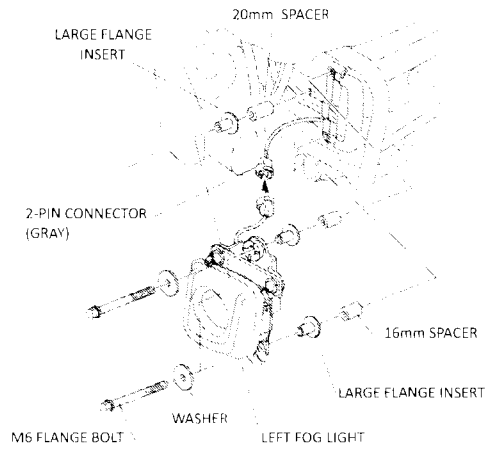

**Note:** There are six 2mm spacers in this kit. These extra spacers are for fine adjustment of your fog light as needed.

**STEP 15.** Remove the parts as shown.

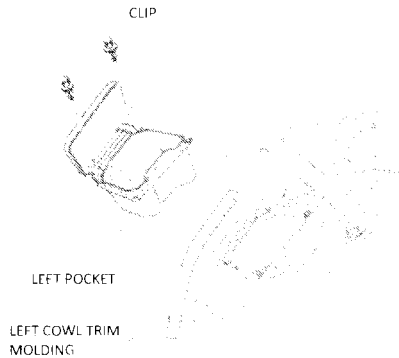

**STEP 16.** Remove the radio control panel.

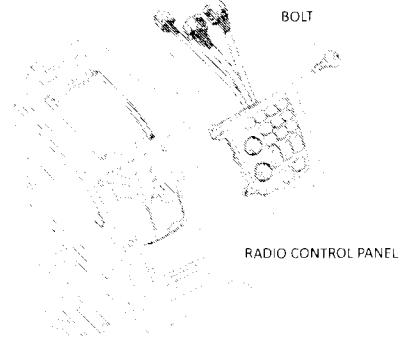

**STEP 17.**

Remove the cover and cap as shown.

**STEP 18.**

Install the fog light on/off switch as shown. The switch remains illuminated whether the fog light is OFF or ON.

**STEP 19.** Reinstall the cover in the reverse order of removal and route the harness as shown.

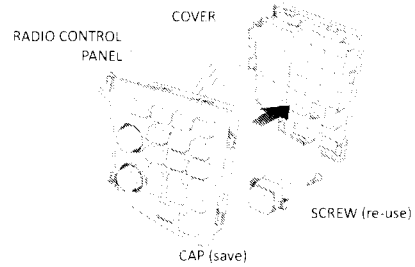

**STEP 20.**

Plug the 4-pin switch connector into relay harness. Plug the relay harness into the motorcycle's accessory 4-pin connector. Secure relay and sub harness with wire tie.

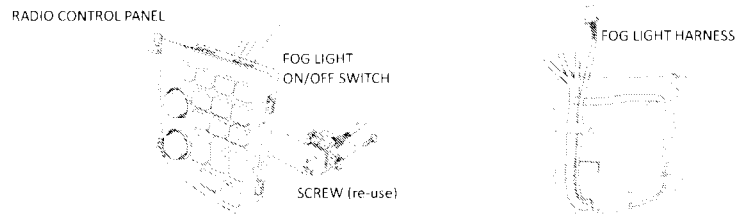

**Note:** This kit comes with jumper plug. **When using the jumper plug in place of the relay the fog lights will only turn off with the switch and ignition. With the relay in place the fog lights will turn off when the high beams are turned on.**

**STEP 21.** Place the relay and fog light sub harness in the gap as shown.

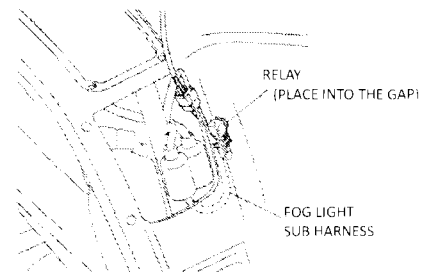
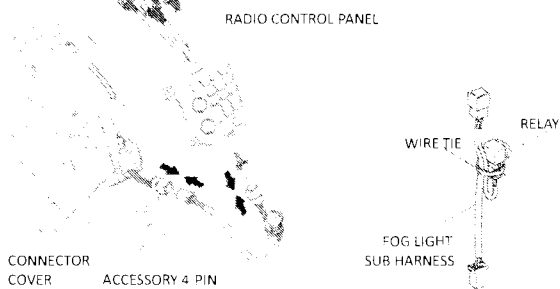

**STEP 22.** Reinstall the radio control panel and left cowl trim molding in the reverse order of removal.

**STEP 23.** Refer to step 9. Remove the Right pocket.

**STEP 24.** Carefully pull the mirror boot away from the front fairing and fold over the mirror housing.

**STEP 25.** Remove the three screws (5MM x 20MM), bracket, and mirror from the mounting bracket.

Note: The mirrors can be swung forward and backward to allow access to the screws.

**STEP 26.** Feed the wire up through the fairing to the mirror. (You may need to remove the three push pins on each side of the inner fairing and pull inner fairing out to facilitate feeding this wire.)

**STEP 27.** Attach one of the enclosed posi tap connectors to each turn signal wire on GL. Right side is light blue, Left side is orange on 2012 Gen 2 GL1800. Reconnect negative terminal of battery. (Verify the correct wire by using a voltmeter.)

**Attach yellow wire** from each fog light to the associated connector. Turn on ignition. Check the amber U shaped light on each fog light. (SEE IMAGE A BELOW FOR STEPS) **IMPORTANT:** You must make sure that the wire makes a complete connection and is secured when you insert and tighten the Posi-Tap otherwise no contact will be made.

**STEP 28.** Attach one of the enclosed posi tap connectors to each position light wire on GL. Right side is blue and white, left side is orange and white on 2012 Gen 2 GL1800. (Verify the correct wire by using a voltmeter.)

**Attach white wire** from each fog light to the associated connector. Turn on ignition. Check the white U shaped light in each Fog Light. (SEE IMAGE A BELOW FOR STEPS)

**STEP 29.** Reinstall the Right Mirror and Right Pocket in the reverse order of removal. Repeat steps 19 through 24 for the Left side.

**STEP 30.** Place the bike on a level ground, about 16 feet (5 meters) away from a wall.

**STEP 31.** Turn ignition on. Turn on fog light.

**STEP 32. LIGHTING ADJUSTMENT**

**A.** Measure the height from the ground to the center of fog light.

**B.** Using a pencil, make a mark of the fog light mounting height on the wall.

**C.** Screw in or out the adjustment screw on each mounting bracket to aim the fog light.

**STEP 33.** Reinstall the front lower cowl in the reverse order of removal. Installation is now complete.

**SIMPLE TROUBLESHOOTING: LEDS NOT "ON"**

- CONFIRM THAT THE LIGHTS ARE WORKING PROPERLY AFTER YOU START THE MOTORCYCLE ENGINE IN A WELL VENTILATED AREA.
- POSI-TAP: MUST BE CORRECTLY TIGHTENED AND FITTED.

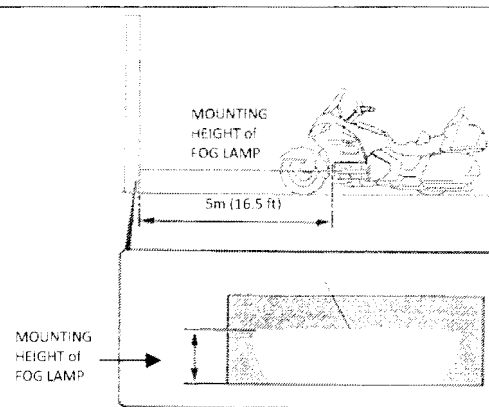

Disclaimer: Please follow the instructions and use care and proper judgment when installing this product. Maximum liability is limited to the purchase price of the product sold. Visit SoCalMotoGear.com for additional warranty information.

#### IMAGE A

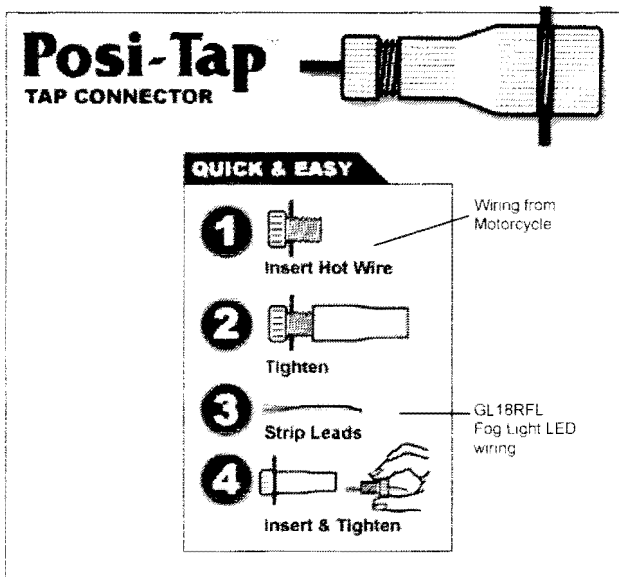

**IMPORTANT:** You must make sure that the wire makes a complete connection and is secured when you insert and tighten the Posi-Tap.

#### HONDA VALKYRIE F6C OWNERS PLEASE READ:

##### DRL AMBER FUNCTION LIMITATION ON F6C BIKES.

Due to factory design, low voltage power being supplied on the bike to the turn signals on the F6C will not properly illuminate the (AMBER LEDs) on the Fog Lights.

Do NOT connect the "Yellow" (AMBER) LED from the GL18RFL Fog Light because there is not enough power to light the turn signal LED feature of the product. Simply wrap up the YELLOW wire with electrical tape to terminate the end of the wire. Do this on both Left and Right Fog Lights. Only the WHITE wire (DRLS) is being used.

The "White" cable which activates the "White" LEDs on the fog lights can be connected to the "ACC" (+) on the motorcycle's relay box. The white DRLs will always stay on whenever there is power to your bike.

\*\*Please check your state/local laws regarding the usage of these lights as they will always remain on as soon as there is power such as turning the key on your bike.\*\*

**WATCH INSTALLATION VIDEO:** [VALKYRIE F6C]  
[www.SocalMotoGear.com/f6cvideo](http://www.SocalMotoGear.com/f6cvideo)

The Posi-Tap™ installation information above is provided for installation purposes. All trademarks and registered trademarks are the property of their respective owners