

PARTS LIST

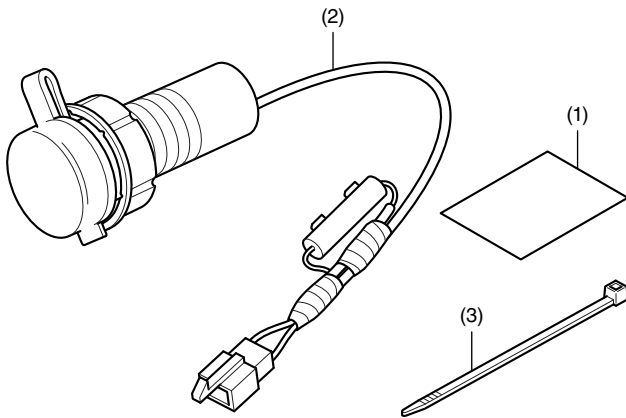

No.	Description	Qty
(1)	Installation Instruction URL	1
(2)	Accessory socket	1
(3)	Wire tie	1

SUPPLIES REQUIRED

Electric drill
Holesaw (30 mm)
Side cutters
Marker
Ruler
File

TORQUE CHART

Refer to the Service Manual for the torque values of the removed parts.

INSTALLATION

NOTE:

- Disconnect the negative (-) cable from the battery before installing this accessory.
- After turning the ignition switch OFF, wait more than 10 seconds and then remove the negative (-) battery cable.
- The memories of the tripmeter and clock will be erased when you disconnect the battery. Reset the clock after reconnecting the battery.
- Reinstall the removed parts on the motorcycle and make sure that the wires and harnesses are not pinched.
- Trim the excess ends off the wire ties after attaching them to the wire harnesses. Do not allow the cut part of the wire tie to interfere with another harness or brake hose.

1. Open the left saddlebag lid as shown.

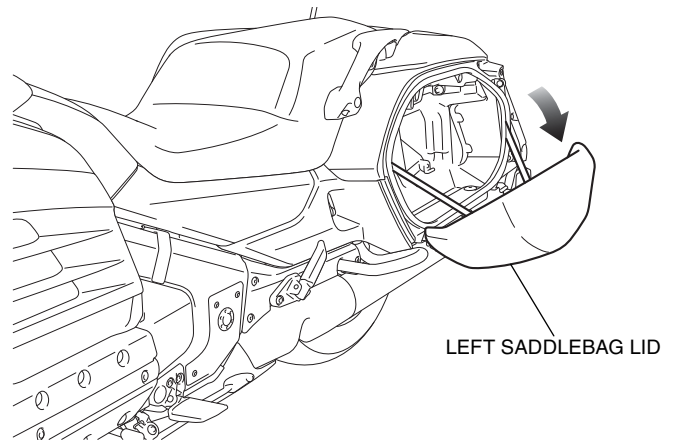

2. Remove the left side cover, and disconnect the negative (-) cable from the battery.

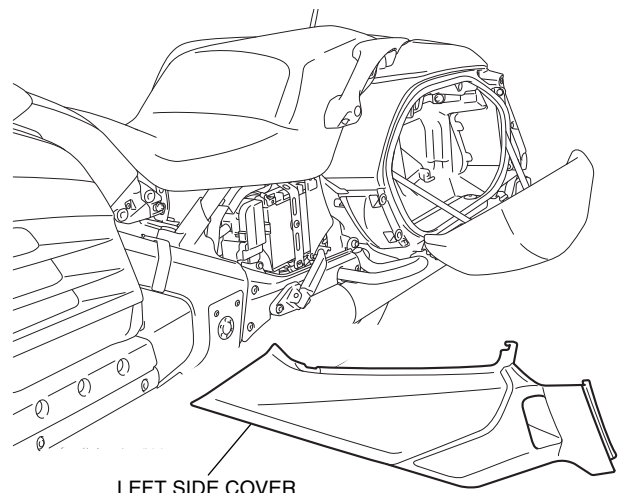

3. Remove the left cowl trim mould as shown.

LEFT COWL
TRIM MOULD

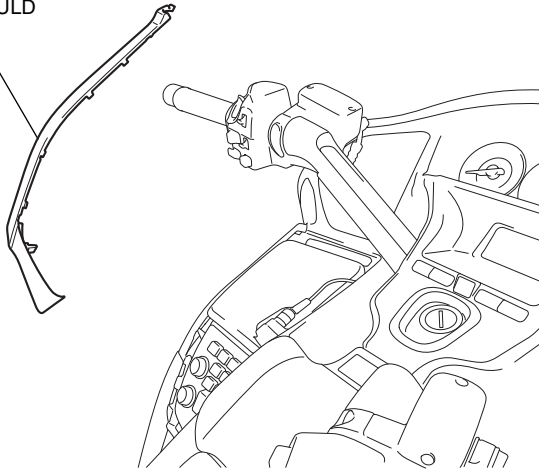

4. Remove the left front pocket as shown.

CLIP

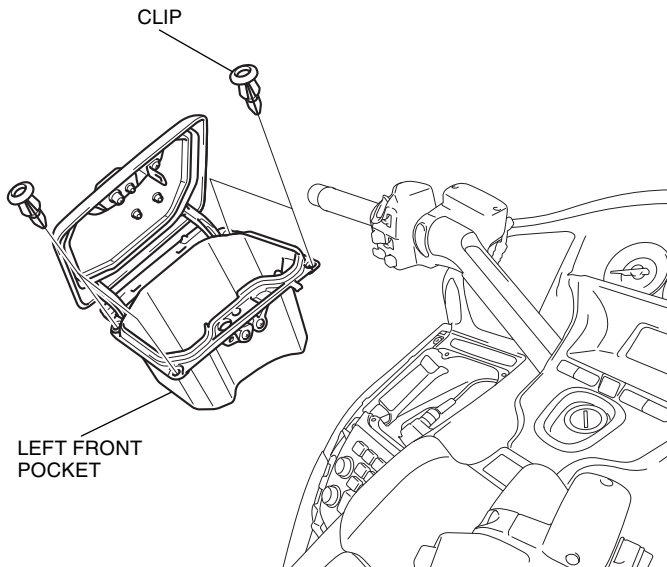

5. Drill at the marked point of the left front pocket as shown.

- Remove any burrs from the edge of the hole.

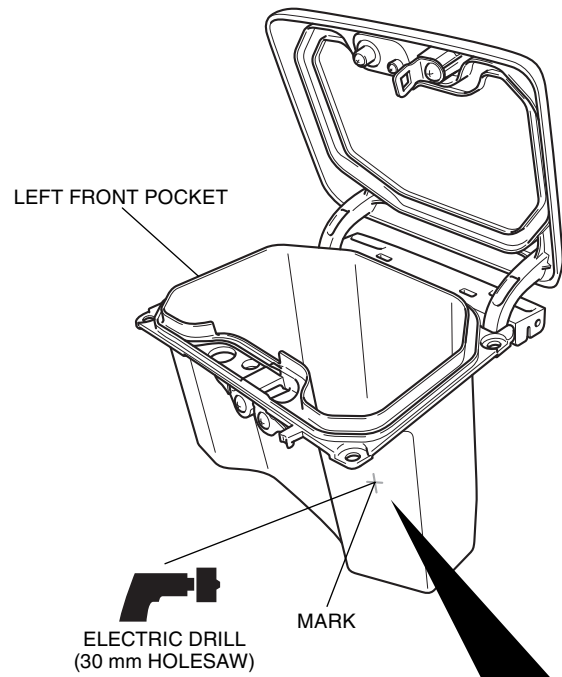

Using a file, remove the  part from the left front pocket.

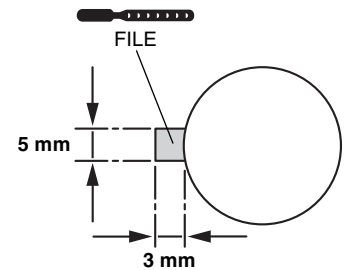

6. Route the accessory socket harness from the inside of the pocket and secure it with the nut as shown.

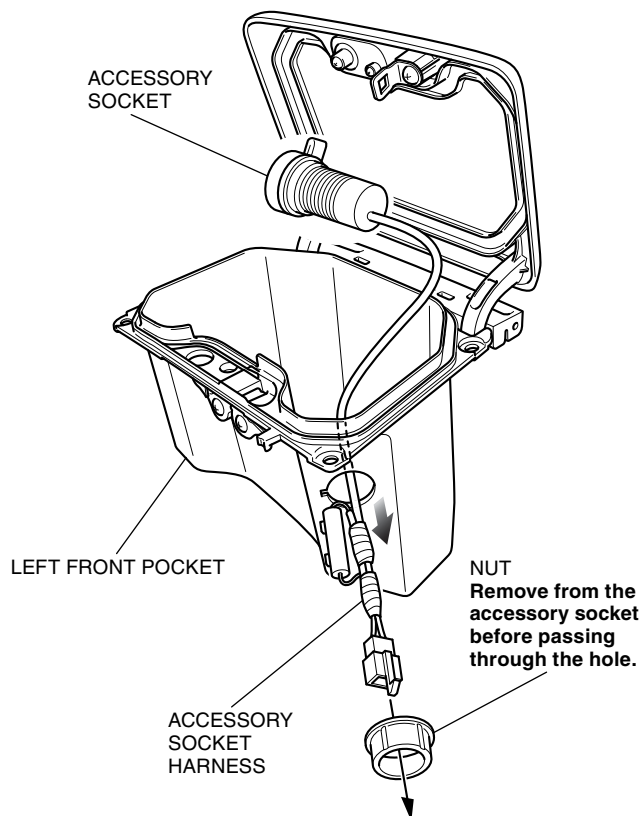

7. Connect the accessory socket harness as shown.

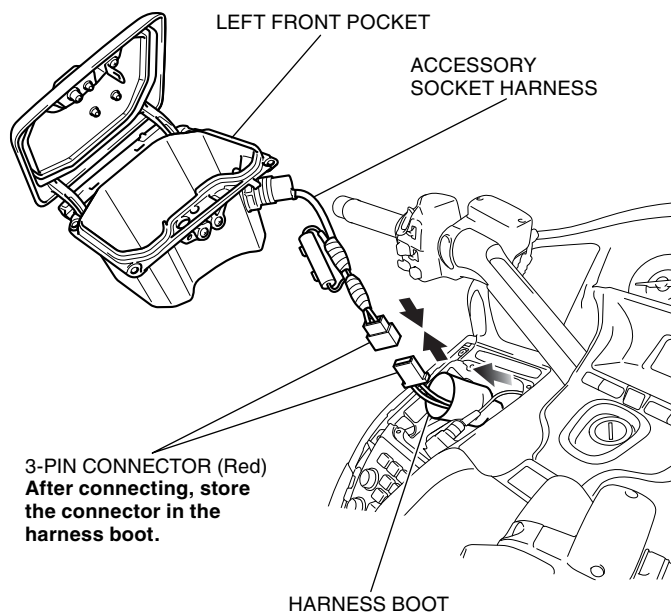

8. Secure the accessory socket harness with the wire tie as shown.

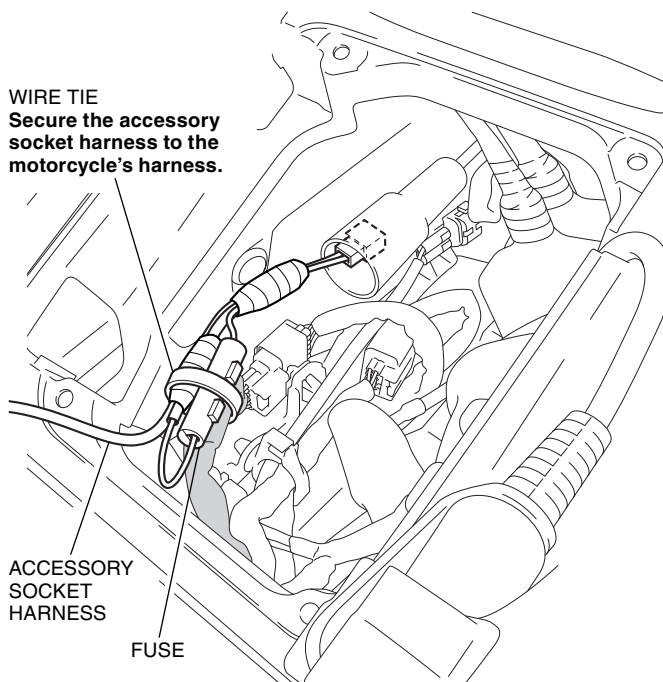

9. Install the motorcycle's parts in reverse order of the removal.

- Confirm that any wire harness is not caught or too tight.