



JMC ROKKER® 400w

4-CH

Amplifier Kit for 2018-2022

Honda® GL-1833

JAMP-400GW18-TB

**Installation
and Operation
Instructions**

Product Description

This new J&M ROKKER 4-channel 400 watt RMS fairing/rear speaker amplifier kit has been designed specifically for use on the 2018-2022 Honda® GoldWing Tour or Standard models.

100% plug-n-play into the Goldwing's electrical system and provides 4 separate channels of amplification at 100 watts RMS continuous power per-channel into a 2 or 3-ohm speaker load.

This is a full range class D digital amplifier properly shielded against RF interference into the AM or FM stereo radio bands.

The ROKKER amplifier uses advanced digital switching power supply technology to dramatically reduce the 12v current demands on the motorcycle electrical system, compared to other brand amplifiers in this power range.

Amplifier mounts to the custom made stainless steel bracket system, to provide solid and secure mounting inside the left saddlebag position.

These new ROKKER series amplifiers come out of the box already dialed in for this specific stock or custom speaker configuration, to provide maximum highway performance from your Goldwing audio system.

Also included are our custom made heavy-gauge power and ground wires used for the fused battery & frame connections, along with all necessary mounting hardware & complete installation/operation instructions.

Amplifier itself measures 7 1/4" Long X 4 3/4" Wide X 1 3/4" Tall.

Installation Instructions

1. Remove the left and right side covers below the seat.
2. Remove the seat.
3. Remove the right and left passenger grab rails below seat. Remove the cable from the left grab rail. **Figure A**
4. Remove the plastic piece right below the passenger back rest. **Figure B**
5. Remove the passenger back rest from the tourpak.

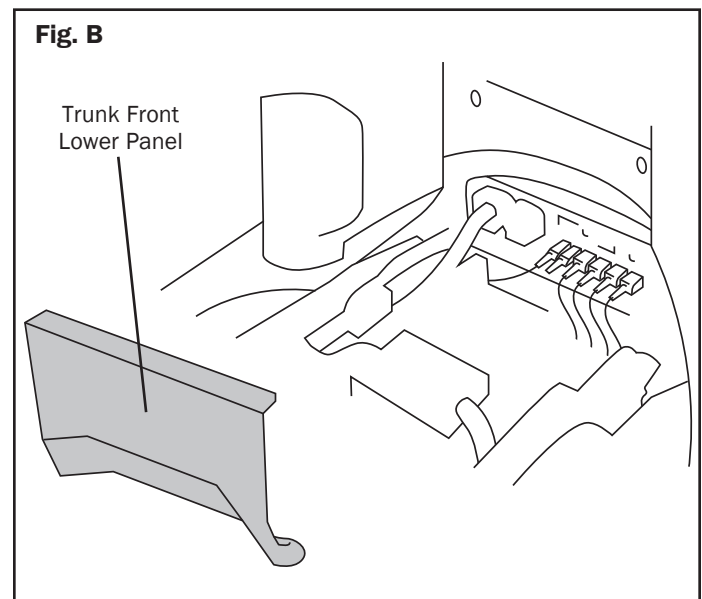
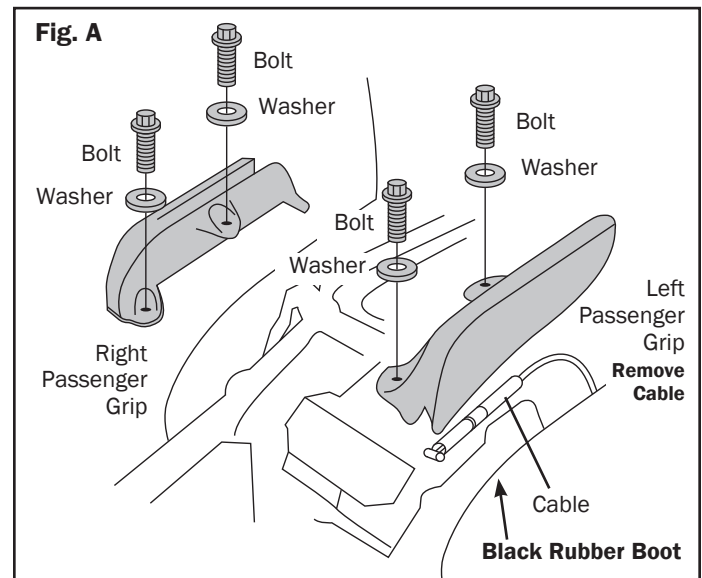

6. Remove the left and right tourpak side covers. **Figure C**

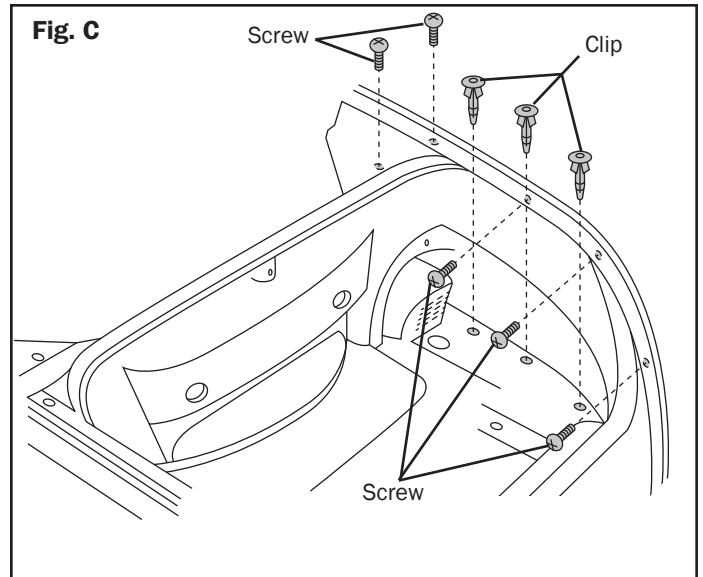

7. Remove the tourpak center lower cover. **Figure D**

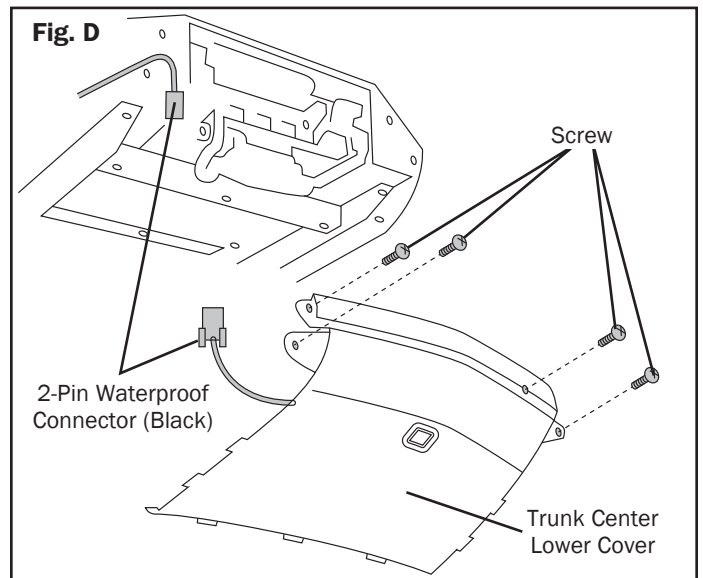

8. Remove the push clips and screws on the left saddle bag upper cover and remove the cover. **Figure E**

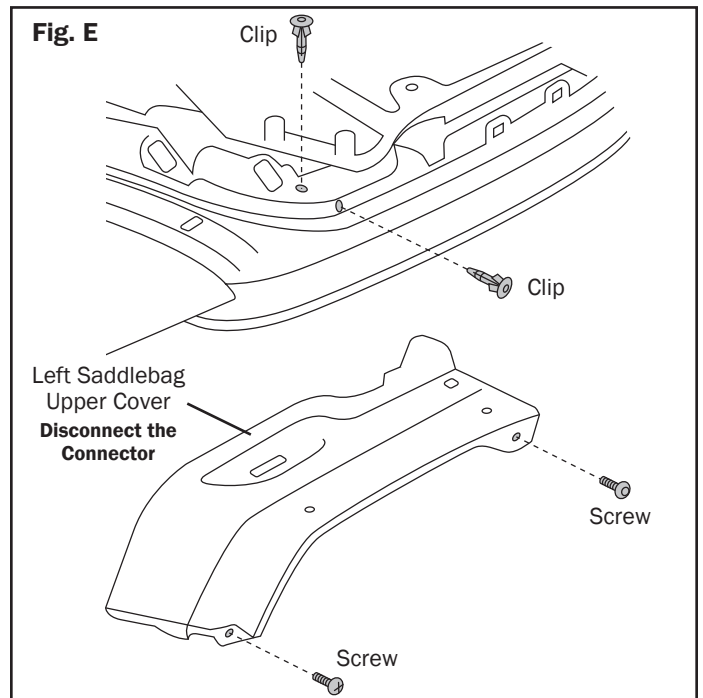

9. Using cutters or Dremel cut out square knockout from the saddle bag latch assembly. **Figure F**

10. Remove the round plastic plug from the top of the saddle bag. **Figure G**

11. Using the amp bracket as a template mark the 3 holes to be drilled. Using a 13/64" bit drill the 3 mounting holes for the amp. One of the mounting holes will line up with the existing hole in the saddle bag by removing the rubber plug. **Figure H**

12. Mount the amp in the saddlebag using the supplied screws, washers, and fiber locking nuts provided.

13. Route the power wire, RCA cables, and output wiring from the amplifier thru both the square knockout **Figure F** and the hole in the top of the saddlebag. **Figure G**

14. Route the Main power wire red to the battery positive post and secure with the stock battery cable using the stock battery terminal screw. Route the black wire to the 10mm bolt holding the battery strap and remove bolt and install ring eyelet under 10mm bolt. Route the orange wire to the accessory fuse terminal and remove the top phillips head screw and install the ring terminal under the phillips head screw. **Figure I**

15. Route the 8 pin connector cables from the ROKKER amp (RCA cables and Main amplifier output cable) to the 8 pin connectors located under the frame on the left side of the motorcycle where the left grab rail was previously installed. Unplug the factory 8-pin connectors (inside black rubber boot) and plug the cables from the amplifier back in series with these 8-pin connectors. **Figure A**

16. Place the RCA adapters under the frame by the main radio under the TourPak.

17. Test the system and then reassemble motorcycle.

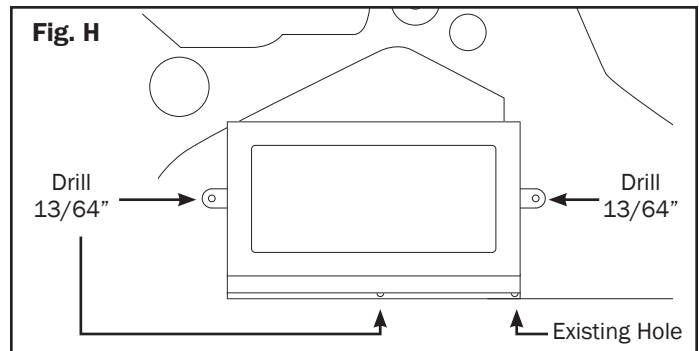
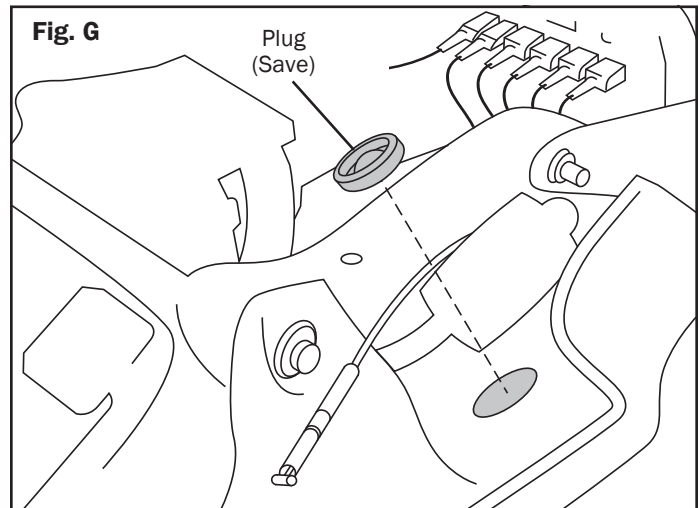
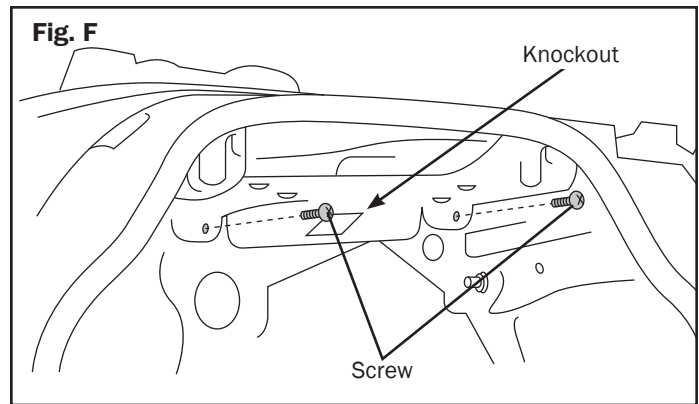

Specifications

ROKKER® 400 4-ch

Full Range Class D Amplifier

Output Power (RMS) @ 2% THD 1000Hz 14.4V CEA 2006
Stereo @ 3ohms 4 x100 Watts - 400w RMS Total
Stereo @ 2ohms 4 x100 Watts - 400w RMS Total
Frequency Response -3dB 20Hz - 24kHz Capable

S/N Ratio >90dB
Separation >74dB
Input Sensitivity .35V - 3.9V
Input Impedance 47.5K

WARRANTY AND REPAIR INFORMATION

TWO YEAR LIMITED WARRANTY In order to facilitate the servicing of this warranty, the Warranty Registration Form should be filled out and returned within 10 days of the date of purchase. However, return of the Warranty Registration Form is not a precondition of this warranty, and this Warranty will be observed by **J&M CORPORATION** whether or not the Warranty Registration Form is returned, on the condition that other satisfactory evidence of the date of the original purchase is provided to **J&M CORPORATION**.

WHO PROVIDES THE WARRANTY? This warranty is provided by **J&M CORPORATION**.

WHO IS PROTECTED? This warranty is extended only to the original owner of this J&M CORPORATION product and may not be transferred or assigned.

WHAT IS COVERED AND HOW LONG? This warranty covers all defects in material or workmanship of our product for a period of 2 years from date of original retail purchase. At its option, **J&M CORPORATION** will repair or replace any defective part(s) or equipment.

The provisions of the warranty shall not apply to any unit which has been subjected to misuse, neglect, incorrect mechanical or electrical installation, unauthorized modifications, accident, nor to units which have been repaired or altered outside of our factory.

PROCEDURE FOR OBTAINING PERFORMANCE OF WARRANTY In the event that the product does not conform to this warranty, the product should be shipped prepaid to the **J&M CORPORATION** service facility. Transportation charges, insurance fees, and labor costs for shipment, removal, or reinstallation of our product are not covered by this warranty. Loss or damage in shipment is the sole responsibility of the freight carrier.

FOR YOUR INFORMATION Repair as provided under this warranty is the exclusive remedy of the consumer. **J&M CORPORATION** shall not be liable for any incidental or consequential damages or for breach of any express or implied warranty on this product. Except to the extent prohibited by applicable law, any implied warranty of merchantability or fitness for a particular purpose on this product is limited in duration to the duration of the warranty. Some states do not allow the exclusion or limitation of incidental or consequential damages, or allow limitations on how long an implied warranty lasts, so the above limitations or exclusion may not apply to you. This warranty gives you specific legal rights which vary from state to state.

J&M CORPORATION reserves the right to make changes in design and to make improvements in its products without the obligation to incorporate the changes or improvements in any of its previously manufactured products.

J&M CORPORATION has not authorized anyone to make representations or warranties other than the warranty contained herein.

The above warranty is effective for all products manufactured after 10/01/86.

NON-WARRANTY REPAIR RATES **J&M CORPORATION** reserves the right to change the labor repair rates without prior notice. At the time of this printing the out-of-warranty repair is \$40 per hour for labor only. However, the customer is advised to verify the current rate when he/she calls customer service to obtain the return authorization number.

FACTORY SERVICE ADDRESS J&M Corporation, 1415 S. Cherry Avenue, Tucson, Arizona, 85713, U.S.A. Tel: 1-800-358-0881 audio@jmc corp.com www.jmc corp.com

CUSTOMER SERVICE NUMBER 1-800-358-0881

Thank you for the confidence you have shown in J&M Corporation by purchasing one of our innovative products.

If you have any question or comments about this product, you may contact us at USA 1-520-624-7000 Monday thru Friday, 8:00AM thru 5:00PM Mountain Standard Time.



1415 S. Cherry Avenue

Tucson, AZ 85713 U.S.A.

Tel (800) 358-0881

Website: <http://www.jmc corp.com>

E-mail: audio@jmc corp.com



WARRANTY REGISTRATION FORM

Please fill out this card completely and mail it immediately after purchase. Please be sure that your zip code and serial number (if applicable) are legible. This will help us to serve you better.

(PLEASE PRINT)

Name _____

Address _____

City _____ State _____ Zip _____

Motorcycle Other E-mail _____

Make _____ Model _____ Year _____

Product part number _____

Serial number (if applicable) _____

Date of purchase _____

Name of dealer it was purchased from _____



Mail to:
JM Corporation 1415 S.
Cherry Avenue Tucson,
AZ 85713
U.S.A.