

INSTALLATION INSTRUCTIONS

GL1800 LED FOG LIGHT KIT

2001-2010 PART NO. GL18FGN (NON-AIRBAG)
 2006-2010 PART NO. GL18FGA (WITH AIRBAG)
 2012-2017 PART NO. GL18FGA (WITH OR WITHOUT AIRBAG)

PATHFINDER L.E.D.®

"Riding at Night has Never Been Brighter"



STOP! IF YOU NEED SERVICE OR SUPPORT – DO NOT RETURN PRODUCT TO STORE
 FOR SERVICE / SUPPORT CONTACT: Service@SoCalMotoGear.com

Congratulations on your purchase!

This product is intended for aftermarket use and have been fit checked on stock, non-modified OEM motorcycles. As with any aftermarket products, there may be some slight modifications required. If you are not comfortable with any installation steps, please consult a qualified motorcycle technician to perform the work. Always allow bulbs to cool down before touching them.

Non U.S. Motorcycles: This kit may not be Plug 'N Play on non U. S. spec motorcycles.

PARTS LIST	LETTER	QTY
LED FOG LIGHT	A	2
RIGHT MOUNTING BRACKET	B	1
LEFT MOUNTING BRACKET	C	1
4MM SPACER	D	3
20MM SPACER	E	1
16MM SPACER	F	2
SMALL FLANGE INSERT	G	4
M5 X 18MM SCRW	H	4
LARGE FLANGE INSERT	I	6
LARGE RUBBER GROMMET W/BRACKET	J	6
2MM SPACER	K	6
M6 FLANGE (LONG) BOLT	L	3
M6 FLANGE (SHORT) BOLT	M	3
JUMPER WIRE [non-pictured]	--	1
SPRING	N	2
M5 X 30MM SCREW [non-pictured]	--	2
FLAT WASHER	O	6
SMALL RUBBER GROMMET W/LIGHT BRACKET [non-pictured]	--	4
ZIP TIE	P	3
ON/OFF SWITCH	Q	1
FOG LIGHT WIRE HARNESS	R	1

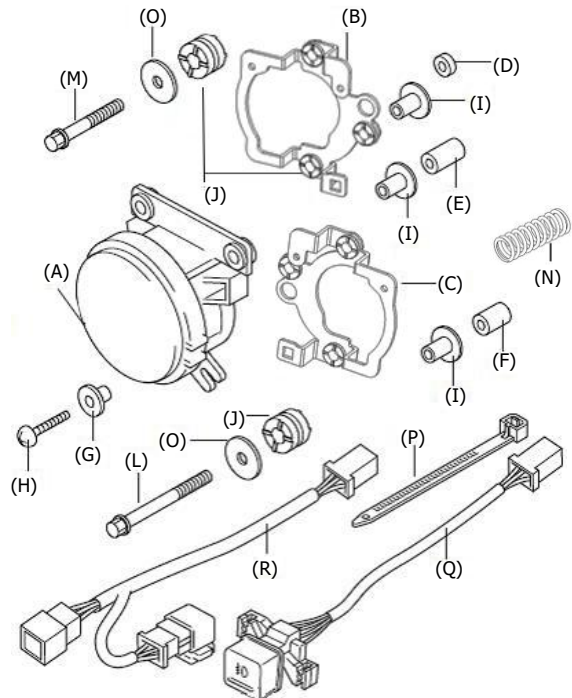

PRE - INSTALLATION REMINDERS:

A. Place motorcycle on center stand.

B. IMPORTANT – The memory settings of the suspension system, trip meter, clock, and radio will be lost when disconnecting the negative battery cable. Reset your settings after reconnecting the battery.

STEP 1. Disconnect the negative cable from the battery.

STEP 2. Remove the lower front cowl following the repair manual instructions.

STEP 3. [Skip this step if you currently have fog lights installed.] Remove your existing lights. Using cutters, remove the plastic knockouts from the lower front cowl and smooth edges with a Dremel® or file.

STEP 4.  Watch our Installation Video: www.SocalMotoGear.com/foglights

To download/view the complete manual, please visit: socalmotogear.com/gl18fgmanual

continued on back...

NOTE: REGARDING RELAY & JUMPER PLUGS

The unit is plug n play and included is a Relay and Jumper plugs. If the relay is used, the kit will function as OEM and the fog lights will turn off with the high beams. If the jumper plug is used, the fog lights will work with both low and high beam headlights.

RE: ITEM "Q" – ON/OFF SWITCH

The fog light ON/OFF switch remains lit whether the fog lights are ON or OFF.

*****Always test the lights to make sure they are working properly before re-assembling and securing your motorcycle.*****

FOLLOW STEPS BELOW FOR LIGHT ADJUSTMENT:

STEP 1. Place the motorcycle on level ground, approximately 16 feet away from a wall.

STEP 2. Turn on the fog light.

STEP 3. Measure the height from the ground to the center of fog light.

STEP 4. Using a pencil, make a mark of the fog light mounting height on the wall.

STEP 5. Screw IN or OUT the adjustment screw on each mounting bracket to aim the fog light (see image).

IMPORTANT LIGHT ADJUSTMENT TIP:

If the fog light is shining too high after installation, screwing "in" will lower the light.

STEP 6. Reinstall the front lower cowl in the reverse order of removal.

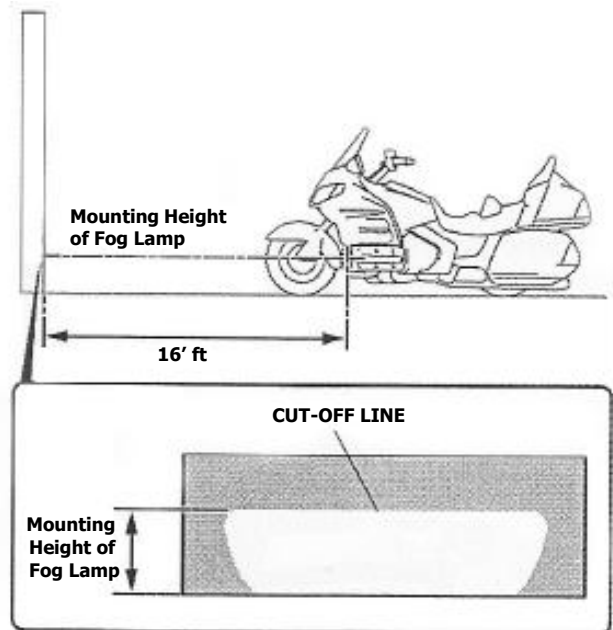

A note regarding Condensation:

Light condensation is completely normal after riding in cold/wet weather and should disappear after a few days. Heavy condensation is water/moisture that remains inside the lens and did not evaporate after a week. In this case, it is covered under warranty. See SoCalMotoGear.com for warranty information.

NOTE: As with many stock and aftermarket parts slight modifications may be required.