

Copyright © 2021 by Big Bike Parts, Inc. No part of this instruction sheet may be reproduced without the written permission of Big Bike Parts, Inc.

PART NO. 52-967

PASSENGER ARMREST KIT

FITMENT: HONDA GOLDWING/GOLDWING TOUR 2020-NEWER

1/28/2021

TOOLS NEEDED: 6MM ALLEN WRENCH

10MM SOCKET

3MM ALLEN WRENCH

REMOVABLE THREAD LOCK

LARGE PHILLIPS SCREW DRIVER

2MM ALLEN WRENCH

**PLEASE READ THROUGH AND UNDERSTAND THESE INSTRUCTIONS BEFORE BEGINNING. "USE REMOVABLE THREAD LOCK ON ALL FASTENERS"**  
**ESTIMATED INSTALLATION TIME: 60 TO 90 MIN.**

**INSTALLATION:**

1. WITH BOTH SADDLEBAGS OPEN, REMOVE THE SIDE PANELS BY PULLING THEM OUT ON THE FRONT (FIG. 1).
2. USE A 6MM ALLEN WRENCH TO REMOVE THE SEAT BOLT FROM EACH SIDE (FIG. 2 SHOWS LEFT SIDE).
3. DISCONNECT THE SEAT WIRE HARNESS PLUG LOCATED UNDER THE RIGHT SIDE PANEL (FIG. 3). REMOVE THE SEAT BY LIFTING UP ON THE FRONT OF THE SEAT AND PULLING TOWARDS THE FRONT OF THE BIKE.
4. USE A 10MM SOCKET TO REMOVE THE TWO BOLTS MOUNTING THE LEFT GRAB HANDLE TO THE BIKE FRAME (FIG. 4).
5. DISCONNECT THE HELMET LOCK CABLE ON THE LEFT HANDLE BY CAREFULLY PULLING THE WHITE CABLE HOLDER FROM THE HOLDING TABS ON THE INSIDE OF THE LEFT GRAB HANDLE (FIG. 5). ONCE CABLE HOLDER IS FREE, PULL THE TENSION SPRING BACK AND SLIDE THE CABLE OUT OF THE SLOTS IN THE LATCH (FIG. 5). REMOVE LEFT GRAB HANDLE AND SET ON A CLEAN SOFT SURFACE TO PREVENT SCRATCHING.
6. USE FIG. 6 TO DETERMINE THE LEFT AND RIGHT SIDE ARMREST BASE. SET RIGHT ARM REST BASE ASIDE FOR NOW.
7. USE FIG. 7 TO DETERMINE THE LEFT AND RIGHT SIDE ARM WELDMENTS. SET RIGHT ARM WELDMENT ASIDE FOR NOW.
8. ASSEMBLE THE LEFT ARMREST AS SHOWN IN FIG. 8. (**DO NOT INSTALL THE CAP YET**)
9. TO ADJUST THE ARM REST, USE A 6MM ALLEN WRENCH TO TIGHTEN THE PIVOT BOLT (SEEN IN FIG. 8). **BE SURE SET SCREWS ARE LOOSE BEFORE ADJUSTING PIVOT BOLT.** ONLY TIGHTEN ENOUGH TO HOLD ARMREST IN PLACE WHILE STILL ALLOWING ARM REST TO PIVOT AS NEEDED. TIGHTEN SET SCREWS WHEN PIVOT BOLT IS ADJUSTED TO DESIRED TENSION.
10. INSTALL THE CAP WHEN ARM REST IS AS DESIRED (SEEN IN FIG. 8).
11. INSTALL THE LEFT ARMREST ASSEMBLY FROM STEP 8 USING THE BASE MOUNT PLATE AND FOUR M5X16MM BUTTON HEAD SCREWS ON THE LEFT PASSENGER HANDLE (FIG. 9).
12. REPEAT STEP 4 AND 5 IN REVERSE ORDER TO RECONNECT THE HELMET LOCK CABLE ON THE LEFT GRAB HANDLE AND REINSTALL THE LEFT GRAB HANDLE ON THE BIKE.
13. REPEAT STEPS 4 THROUGH 9 ON THE RIGHT SIDE. *THERE IS NO CABLE ON THE RIGHT GRAB HANDLE.*
14. REPEAT STEPS 1 THROUGH 4 IN REVERSE ORDER TO FINISH ASSEMBLING BIKE.

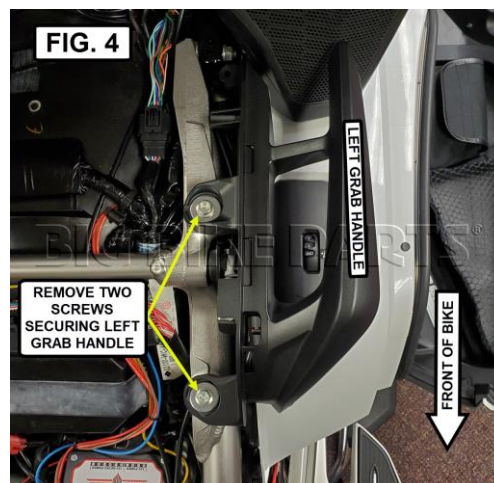
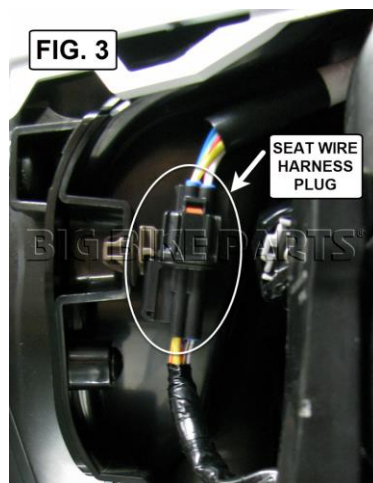
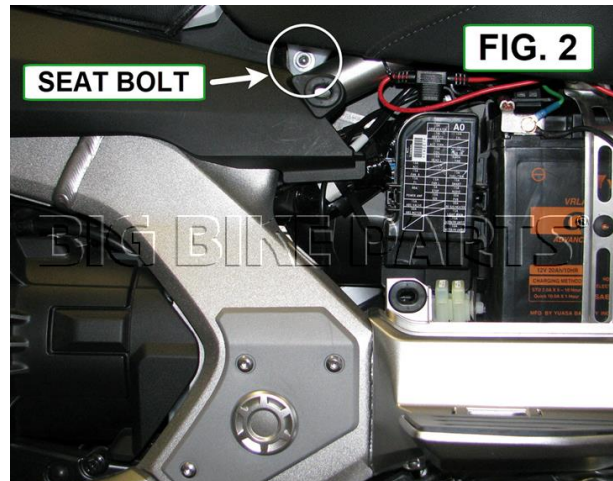

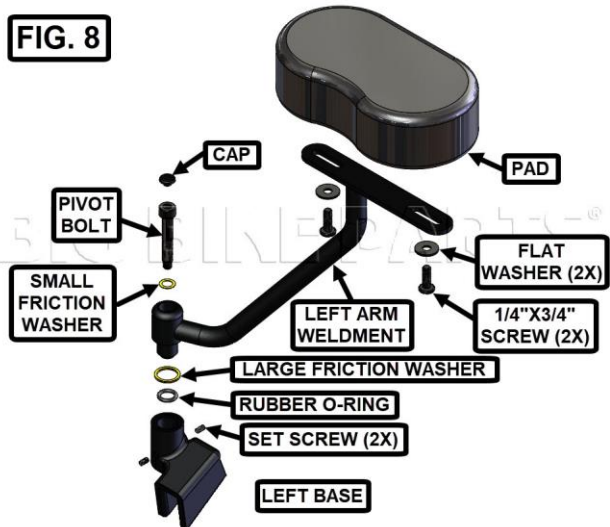
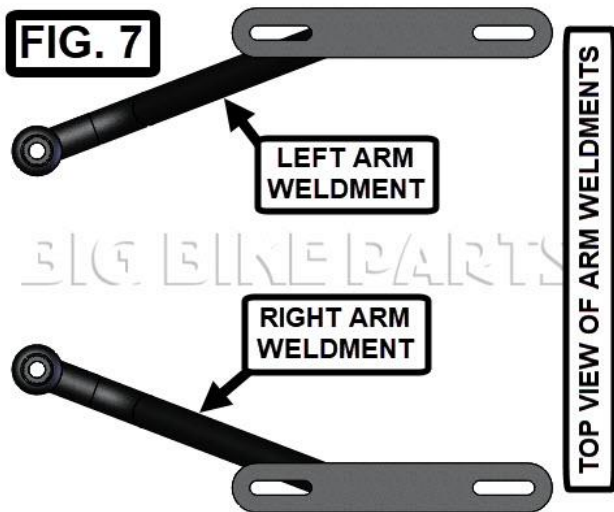
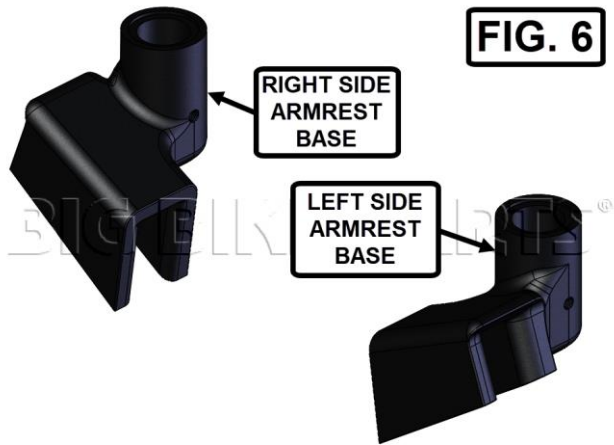
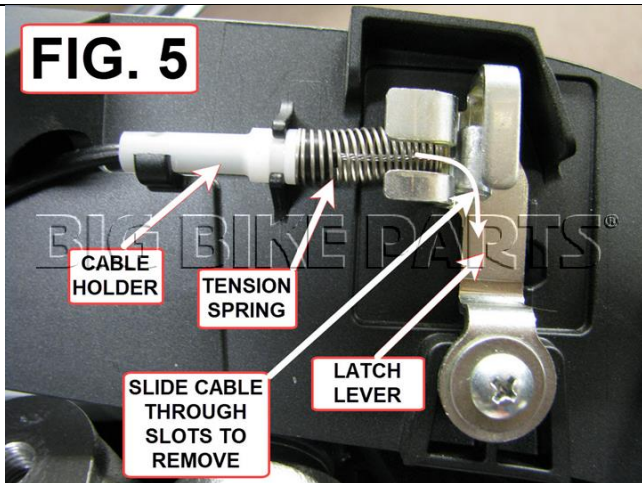

**NOTICE**

IGNORING THE CONTENTS OF THESE INSTRUCTIONS MAY AFFECT THE PRODUCT PERFORMANCE AND FUNCTIONALITY. NOT FOLLOWING THESE INSTRUCTION MAY CAUSE DAMAGE TO THE PRODUCT OR THE VEHICLE TO WHICH IT IS BEING ATTACHED.

**WARNING**

THIS PRODUCT WAS DESIGNED TO BE USED AS A PASSENGER ARMREST ONLY. PASSENGER ARMRESTS ARE NOT SAFETY RESTRAINING DEVICES. DO NOT USE THIS PRODUCT TO ASSIST IN MOUNTING OR DISMOUNTING THE MOTORCYCLE. DO NOT APPLY FULL BODY WEIGHT TO THE ARMREST TO ADJUST SEATING POSITION.

**WARNING**

THREADLOCK CAUSES PLASTICS TO CRACK, BREAK OR BECOME BRITTLE. WHEN USING THREADLOCK TO INSTALL HARDWARE WITH PLASTIC COMPONENTS, ONLY APPLY TO METAL COMPONENTS. IT IS CRITICAL THAT ANY EXCESS THREADLOCKER OR SPILLAGE IS CLEANED COMPLETELY FROM PLASTIC COMPONENTS IMMEDIATELY BEFORE DRYING. A DAMP TOWEL OR RAG IS THE BEST WAY TO ACHIEVE THIS. IF EXCESS THREADLOCKER IS NOT CLEANED UP RIGHT AWAY, IT COULD LEAD TO DAMAGED PRODUCTS AND VOID WARRANTY.