

HONDA

INSTALLATION INSTRUCTIONS

Accessory	Application	Publication No.
DCT FOOT SHIFTER P/N 08U71-MKC-A00	GL1800BD/D/DA	MII 16426
		Issue Date
		January 2018

Honda Dealer: Please give a copy of these instructions to your customer.

PARTS LIST

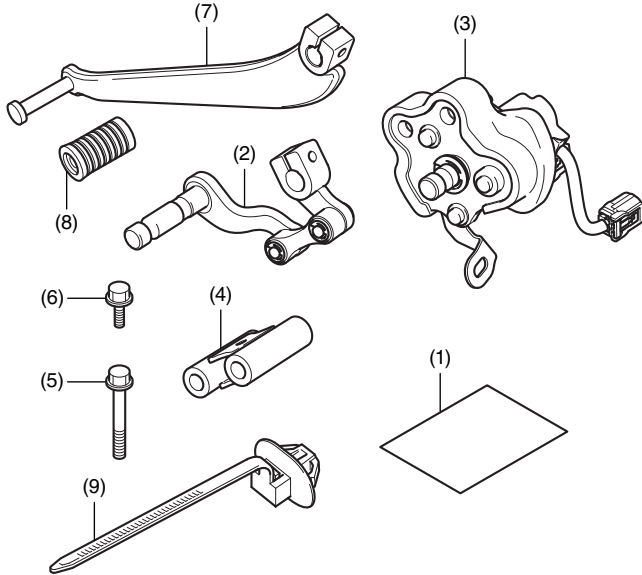

No.	Description	Qty
(1)	Installation Instructions URL	1
(2)	Gear change arm	1
(3)	Gear change switch	1
(4)	Collar	1
(5)	8 mm flange bolt	2
(6)	6 mm flange bolt	2
(7)	Gear change pedal	1
(8)	Rubber toe pad	1
(9)	Clip band	1

TOOLS AND SUPPLIES REQUIRED

- Socket (10 and 12 mm)
- Ratchet
- Snips
- Marker
- Grease
- Ruler
- Torque wrench

TORQUE CHART

Tighten all screws, bolts, and nuts to their specified torque values. Refer to the Service Manual for the torque values of the removed parts.

Item	N-m	kgf-m	lbf-ft
6 mm flange bolt	12	1.2	9
8 mm flange bolt	27	2.8	20

INSTALLATION

▲ CAUTION

- To prevent burns, allow the engine, exhaust system, radiator, etc., to cool before installing the accessory.

NOTE:

- Do not disassemble the gear change switch.
- Disconnect the negative (-) cable from the battery before installing this accessory.
- The memory of the clock will be erased when you disconnect the battery. Reset the clock after reconnecting the battery.
- Trim the excess ends off the wire ties after attaching them to the wire harnesses. Do not allow the cut part of the wire tie to interfere with another harness or brake hose.
- Reinstall the removed parts on the motorcycle and make sure that the wires and harnesses are not pinched.
- Registration is necessary after installing this accessory.

1. Open the left saddlebag lid as shown.

<Left side>

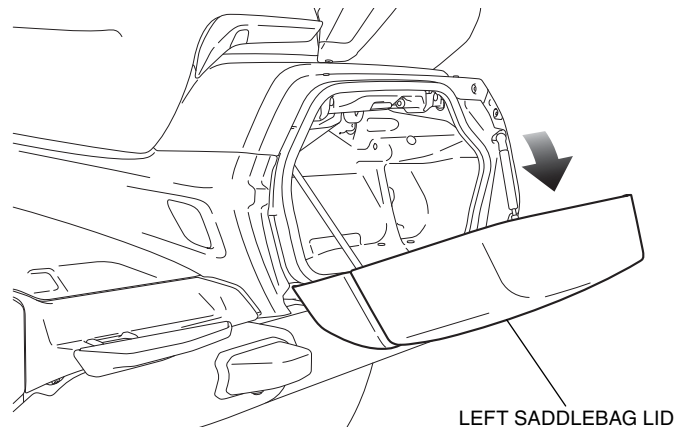

2. Remove the left side cover as shown, and disconnect the negative (-) cable of the battery.

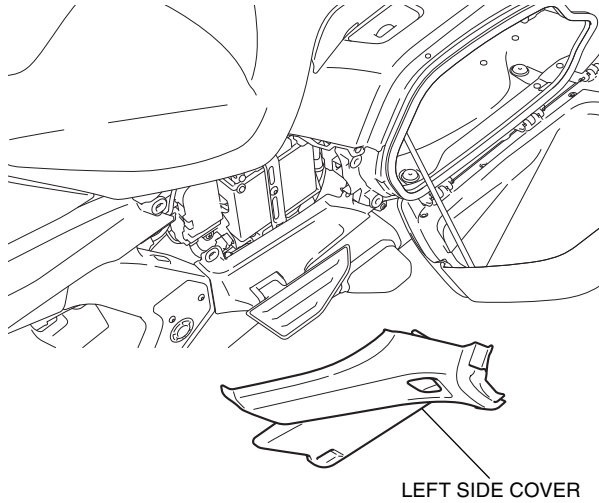

3. Remove the left main step as shown.
<Left side>

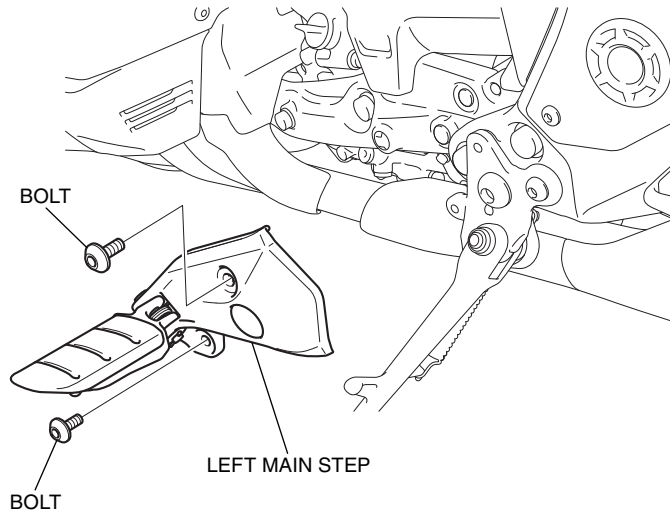

4. Remove the plugs as shown.

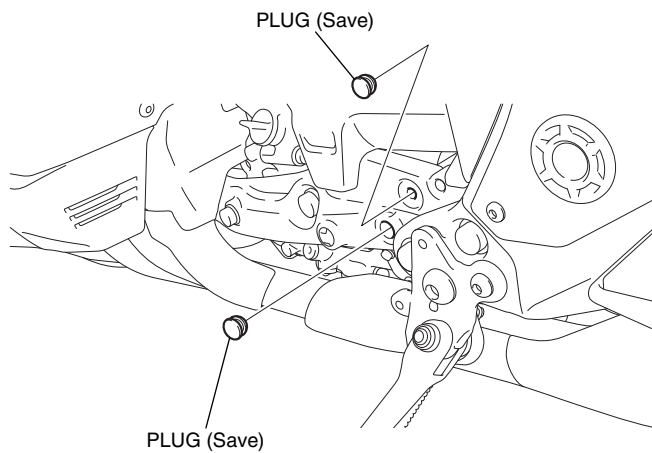

5. Disconnect the connector as shown.

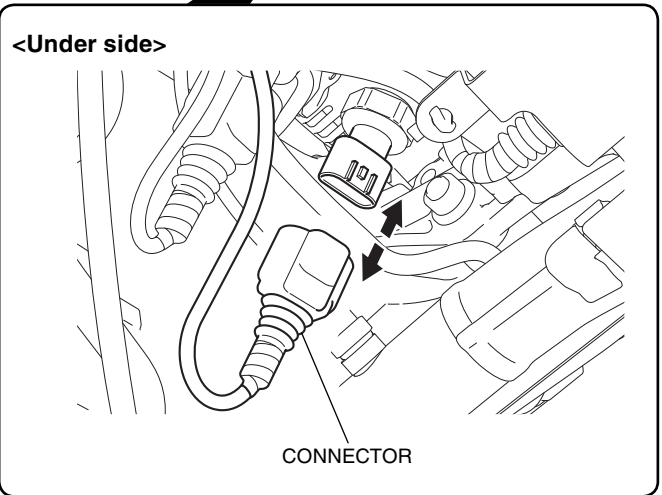
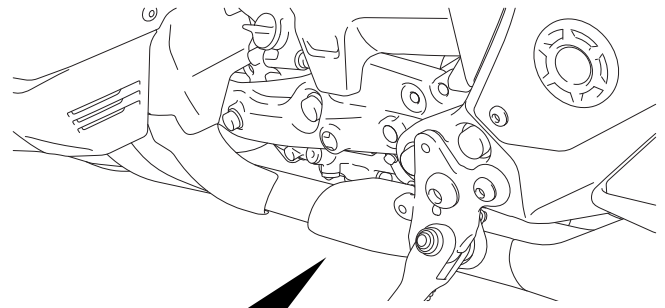

6. Remove the parts as shown.

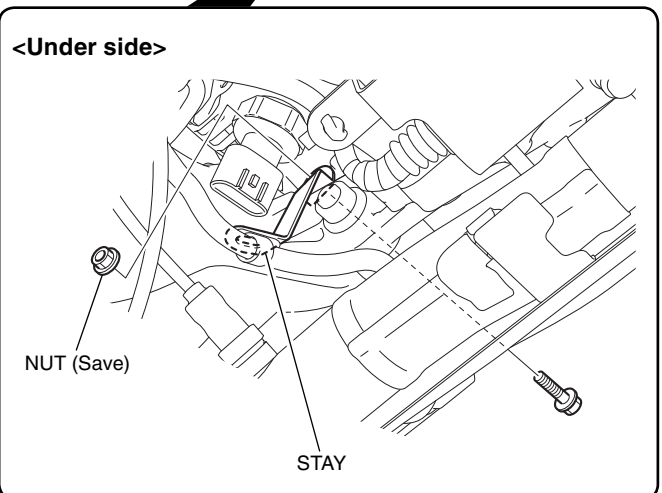
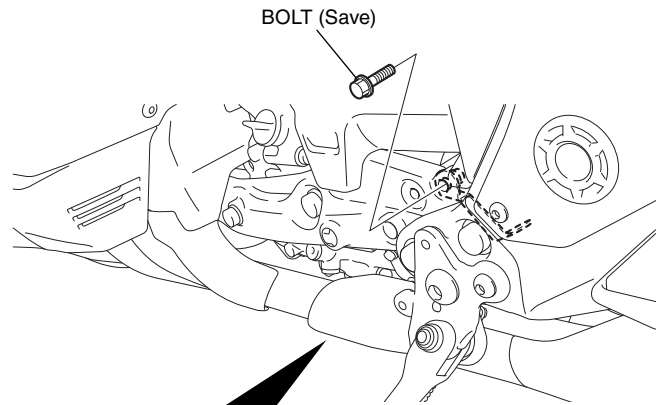

7. Remove the stay as shown.

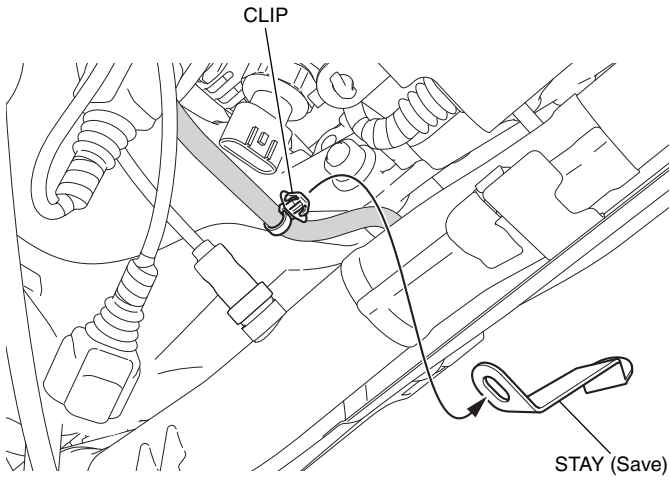

8. Mark the sidestand switch harness in the position shown.

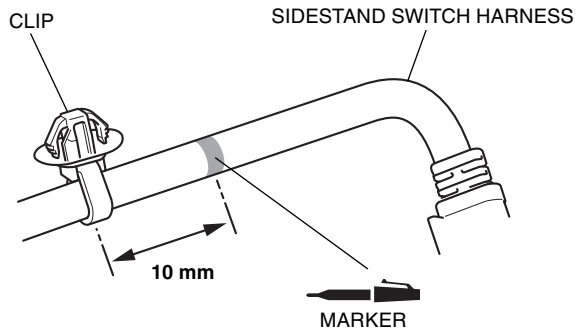

9. Remove the clip, and install the clip band as shown.

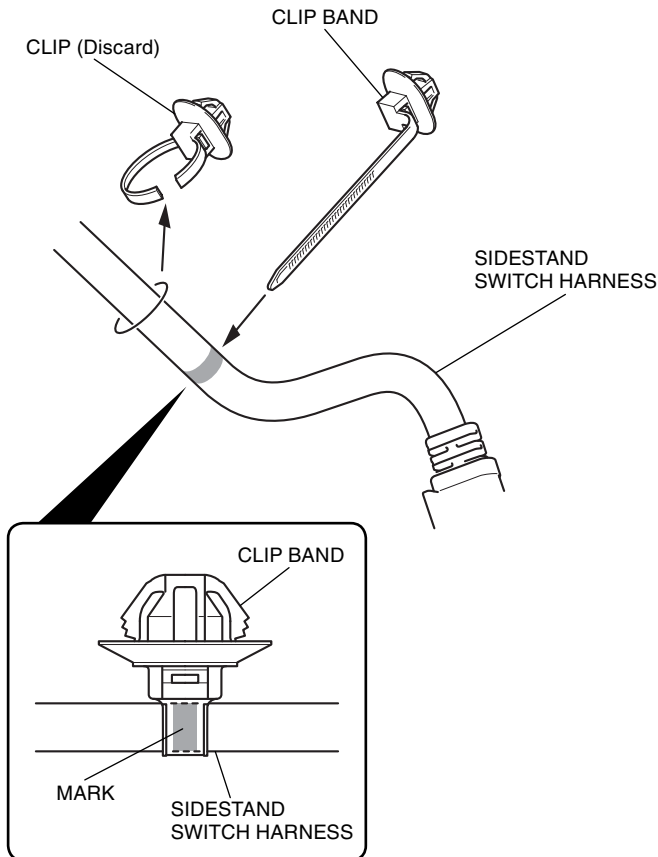

10. Remove the left engine side cover as shown.

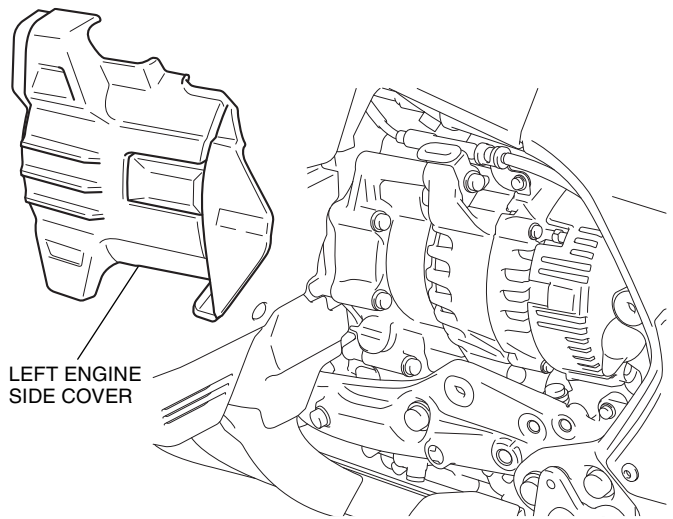

11. Install the gear change arm as shown.

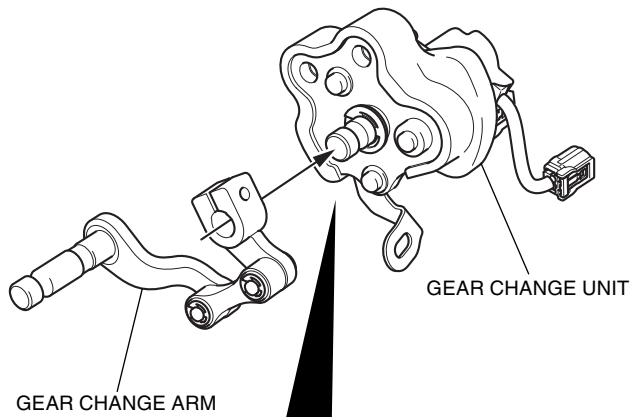

Align the punch mark with the slit of gear change arm as shown.

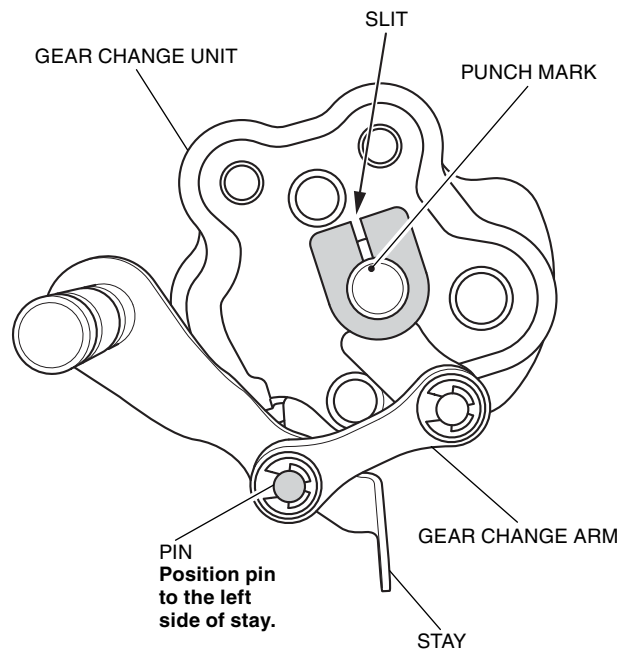

12. Install the 6 mm flange bolt as shown.

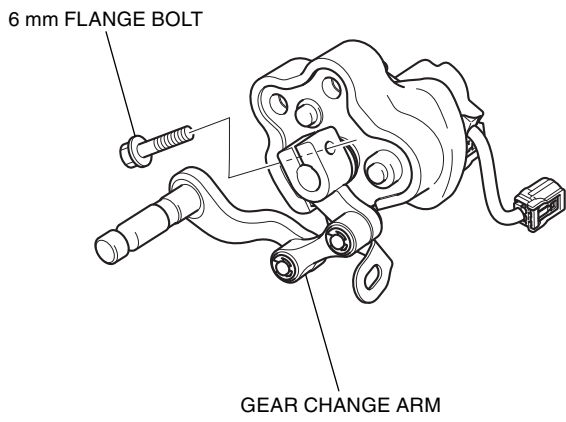

13. Loosely install the collar as shown.

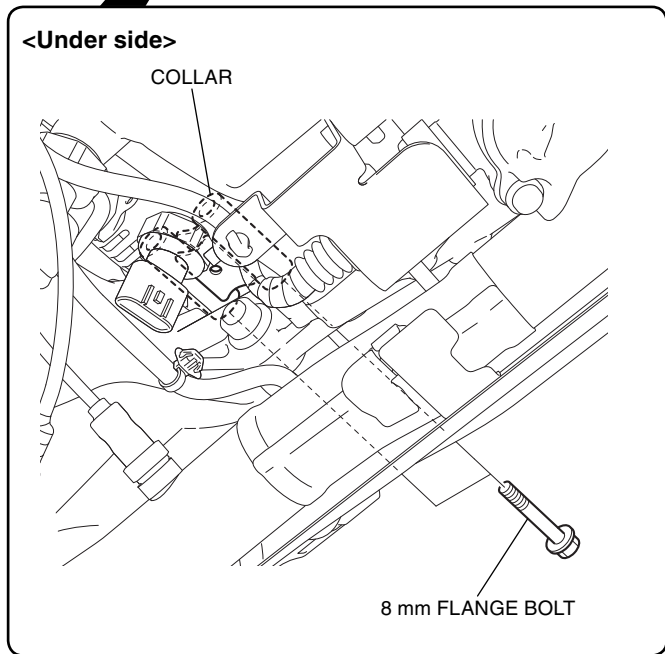
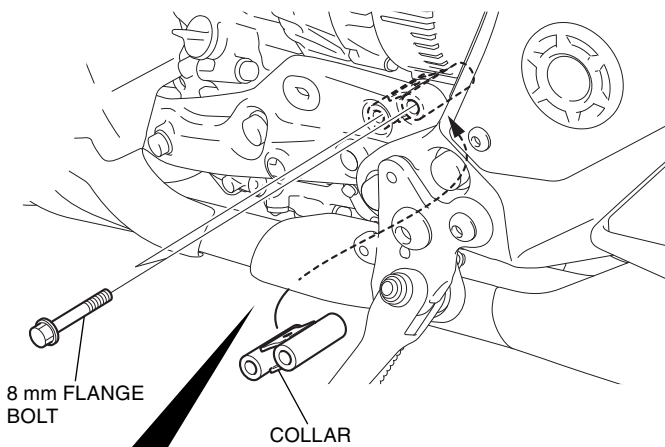

14. Apply grease to the position shown.

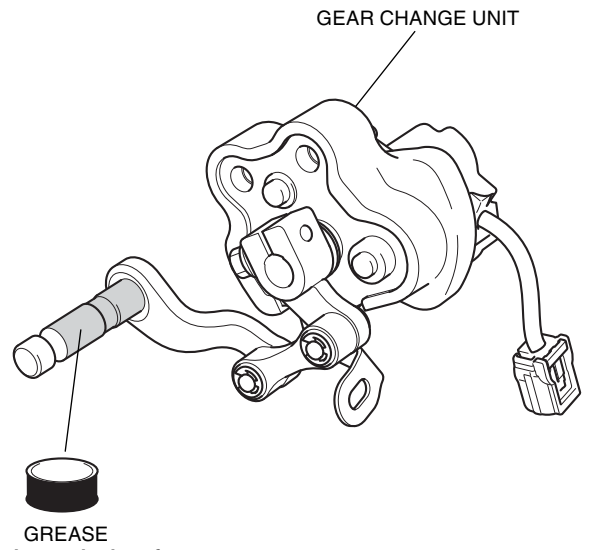

15. Loosely install the gear change unit as shown.

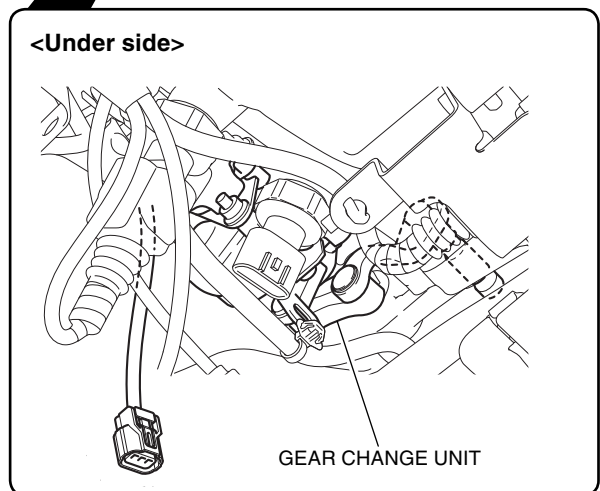
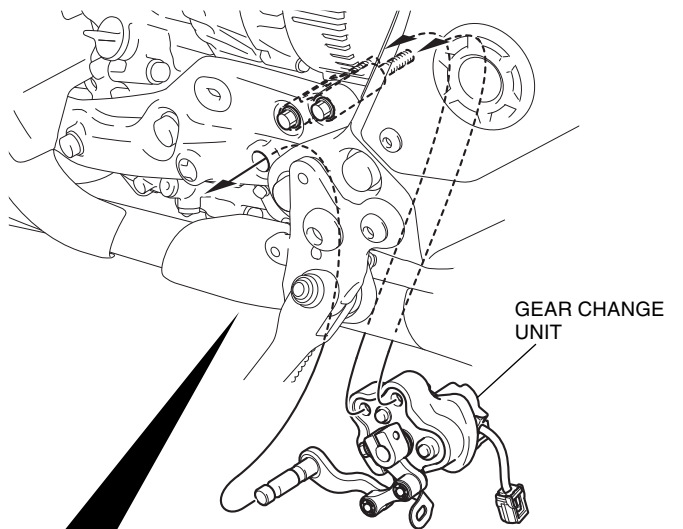

16. Install the rubber toe pad as shown.

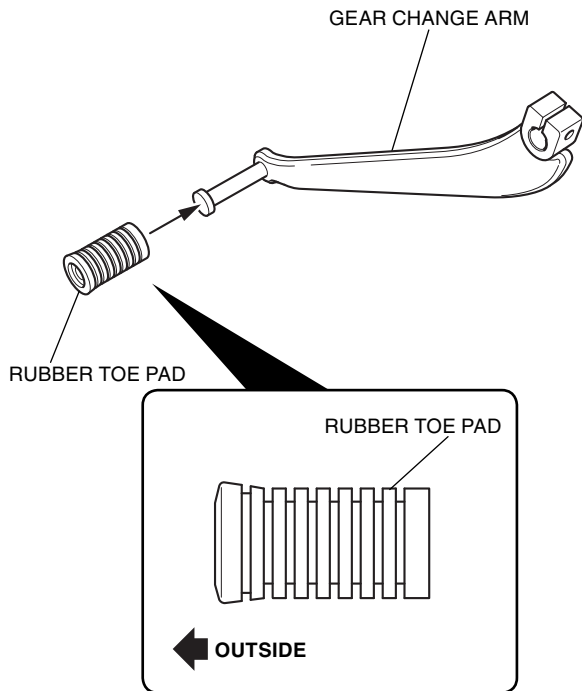

17. Install the gear change arm as shown.

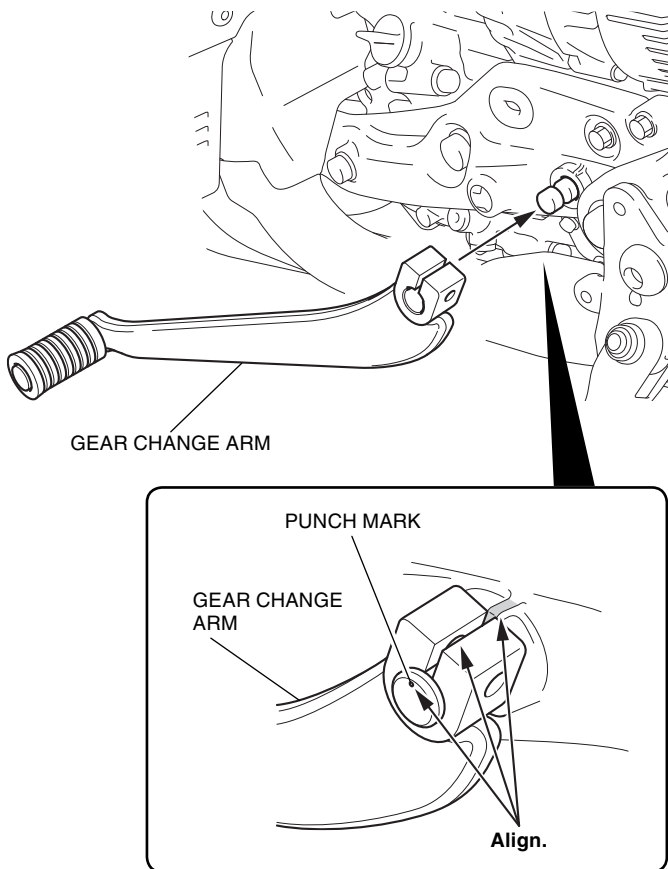

18. Install the 6 mm flange bolt as shown.

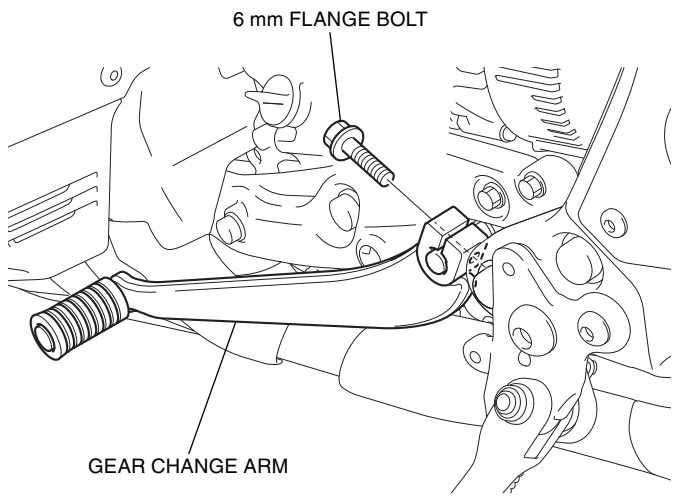

19. Tighten all loosely installed parts securely.

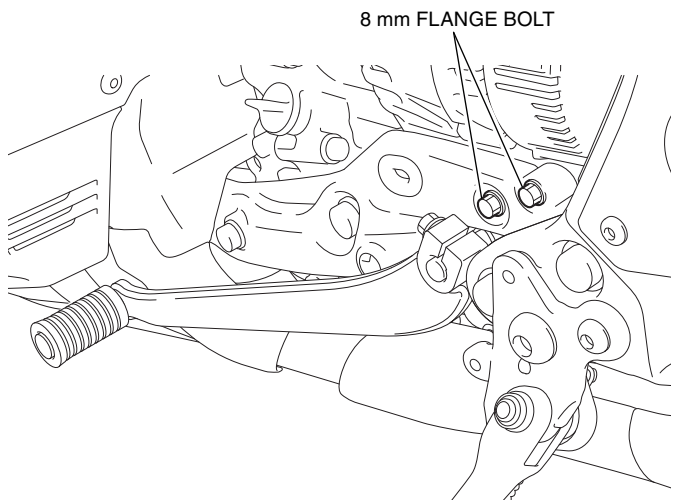

20. Secure the harness as shown.

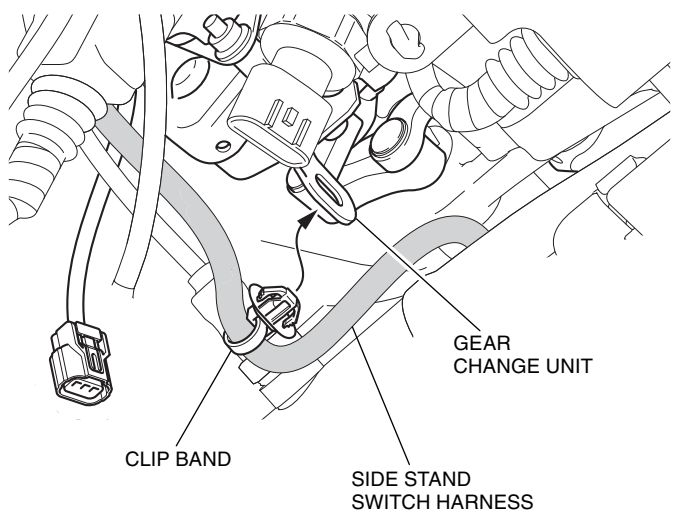

21. Remove the dummy connector as shown.

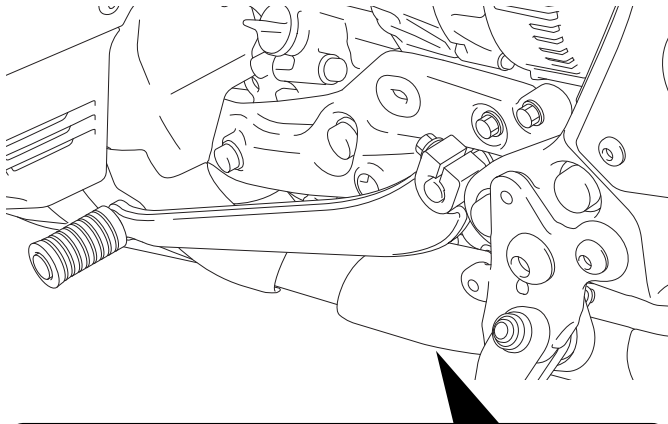

<Under side>

3-PIN WATERPROOF DUMMY
CONNECTOR (Black) (Save)

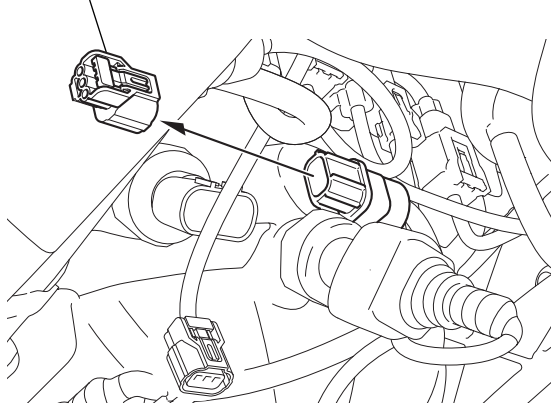

22. Connect the gear change unit harness as shown.

GEAR CHANGE
UNIT HARNESS

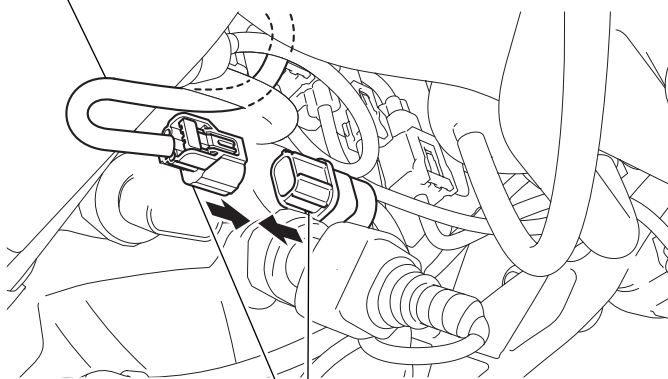

3-PIN WATERPROOF
CONNECTOR (Black)

23. Install the motorcycle's parts in reverse order of the removal.

- **Confirm that any wire harness is not caught or too tight.**

24. Register this accessory to the motorcycle by following the REGISTRATION procedure.

25. Check the headlight and the other lights for proper operation.

REGISTRATION

- Check that this accessory is installed securely.
1. Turn the ignition switch to ON. Mode level indicator blinks after 2 seconds.
 - **Do not start the engine at this time.**
 - **Check that the gear is in neutral.**

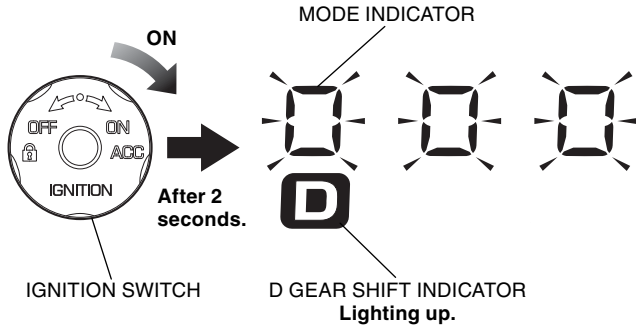

2. Operate the gear change pedal as shown.

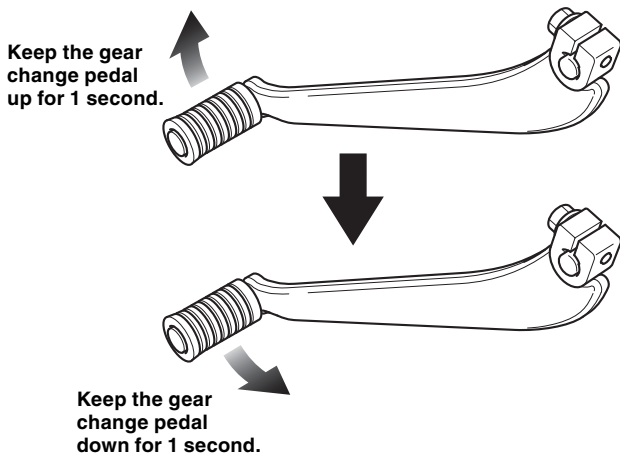

3. Mode indicator lighting up after the registration is completed.

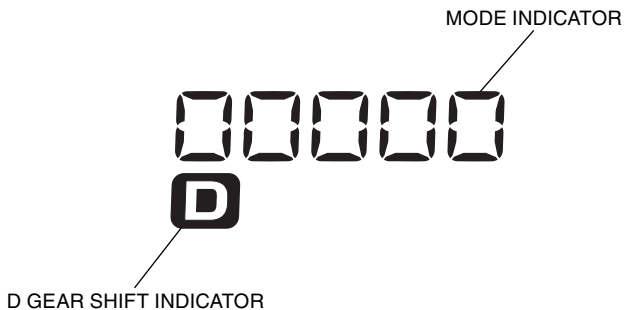

<If the gear shift indicator goes off>

- **Registration is not completed properly. Turn the ignition switch to OFF and perform the registration procedure from step 1.**
4. Turn the ignition switch to OFF.

DEREGISTRATION

- Deregistration is necessary after removing this accessory.
1. Remove this accessory.
 2. Turn the ignition switch to ON while simultaneously pressing both shift switches as shown.
 - **Do not start the engine at this time.**
 - **Check that the gear is in neutral.**

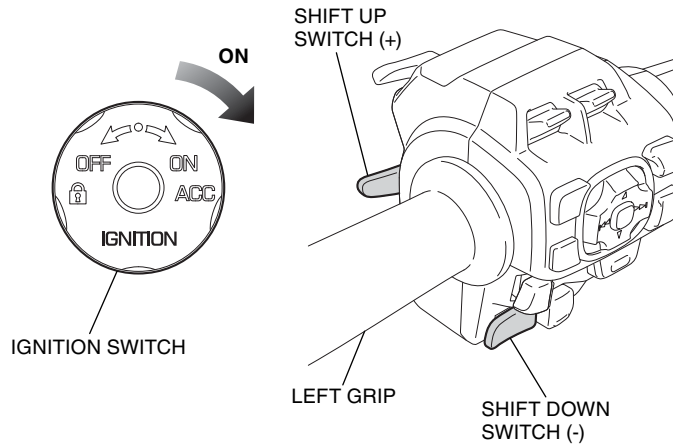

3. Mode indicator blinks.

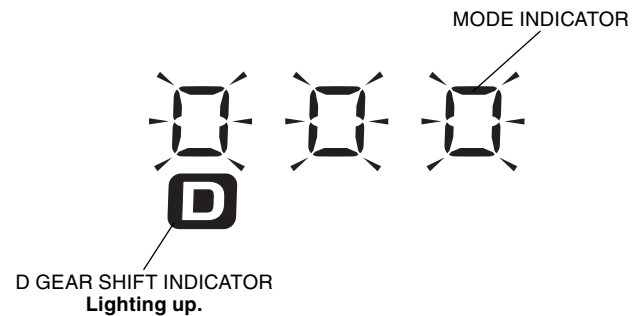

4. Mode indicator lighting up 5 seconds after deregistration is completed.

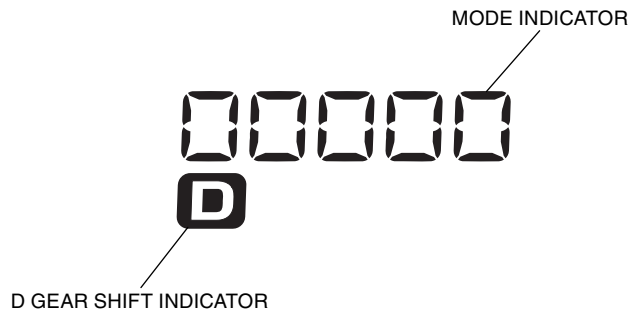

<If the gear shift indicator goes off>

- **Deregistration is not completed properly. Turn the ignition switch to OFF and perform the deregistration procedure from step 2.**
5. Turn the ignition switch to OFF.