



INSTALLATION INSTRUCTIONS

Accessory

CB ANTENNA
P/N 08E85-MKC-A00

Application

GL1800/D/DA

Publication No.

MII 16426

Issue Date

January 2018

Honda Dealer: Please give a copy of these instructions to your customer.

PARTS LIST

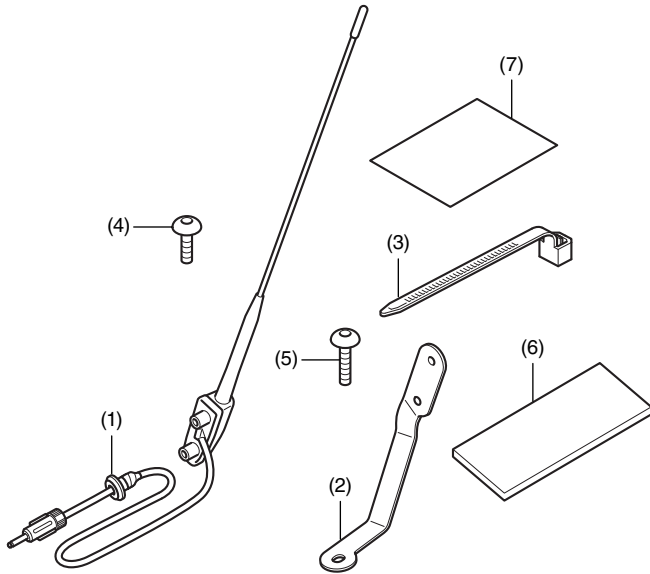

No.	Description	Qty
(1)	CB antenna	1
(2)	CB antenna stay	1
(3)	Wire tie	2
(4)	6 mm socket bolt (short)	2
(5)	6 mm socket bolt (long)	1
(6)	Cushion	2
(7)	Installation Instructions URL	1

TOOLS AND SUPPLIES REQUIRED

Hex wrench (5 mm)

Electric drill

Drill bit (14 mm)

Hole saw (18 mm)

Scale

Marker

Isopropyl alcohol

Shop towel

Torque wrench

TORQUE CHART

Tighten all screws, bolts, and nuts to their specified torque values. Refer to the Service Manual for the torque values of the removed parts.

Item	N·m	kgf·m	lbf·ft
6 mm socket bolt	9	0.9	6.6

INSTALLATION

NOTE:

- Heat the bonding surfaces with a hair dryer if the ambient air temperature is below 70°F (21°C).
- The adhesive reaches full strength in 72 hours. Wait at least 24 hours before riding your motorcycle.
- Disconnect the negative (-) cable from the battery before installing this accessory.
- The memory of the clock will be erased when you disconnect the battery. Reset the clock after reconnecting the battery.
- Reinstall the removed parts on the motorcycle and make sure that the wires and harnesses are not pinched.

1. Install the CB unit.
 - **Perform the step 1 to 24 on the CB Radio (sold separately) installation instructions.**
2. Remove the parts as shown.

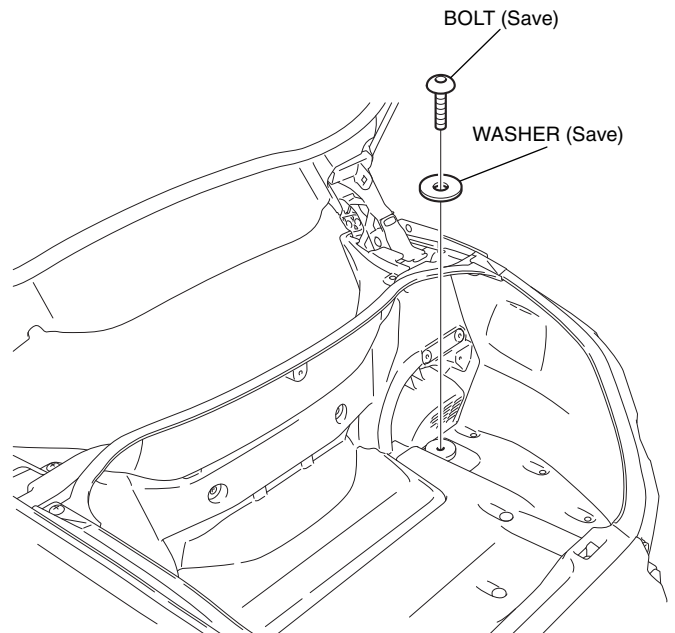

3. Drill a 14 mm hole at each marked line of the trunk inner box as shown.
 - **Drill holes at the center of the marked lines.**
 - **Remove the any burrs from the edge of the hole.**

<Right side>

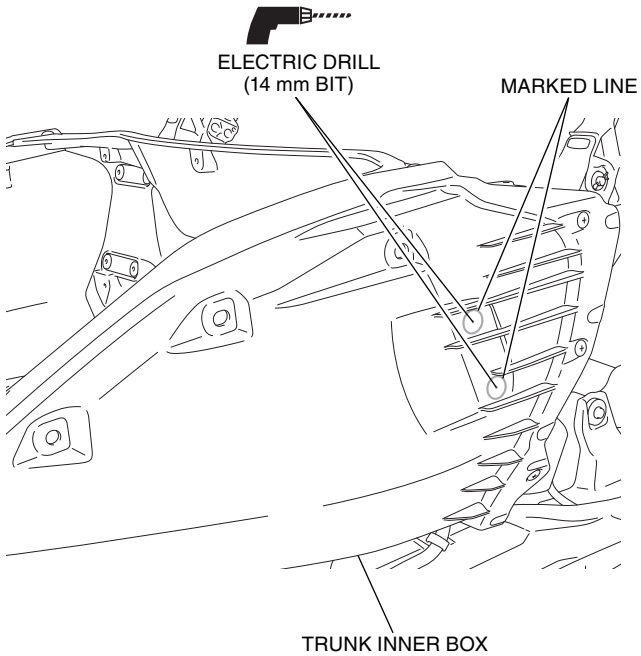

4. Drill a 14 mm hole at each marked line of the right trunk side cover as shown.
 - **Drill holes at the center of the marked lines.**
 - **Remove the any burrs from the edge of the hole.**

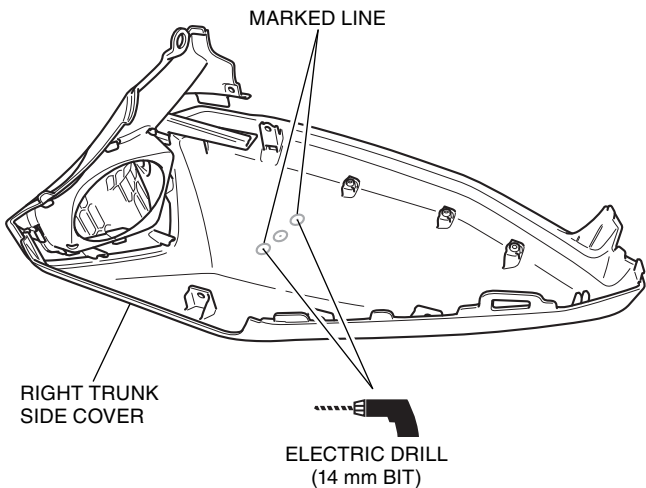

5. Drill an 18 mm hole at the marked line of the right trunk side cover as shown.
 - **Drill hole at the center of the marked line.**
 - **Remove the any burrs from the edge of the hole.**

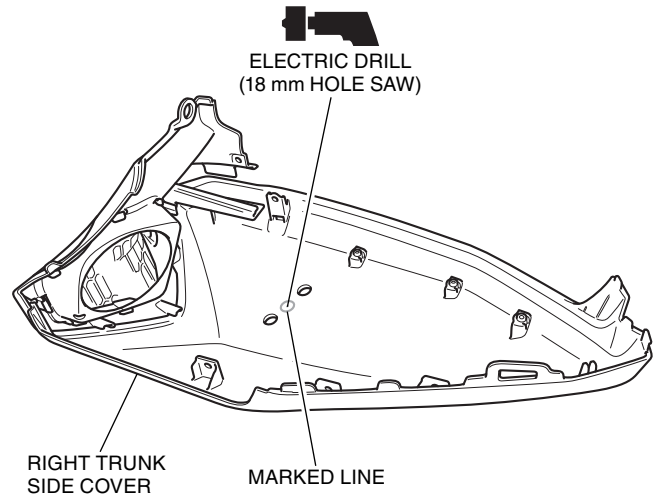

6. Clean the surface of the area shown with isopropyl alcohol.

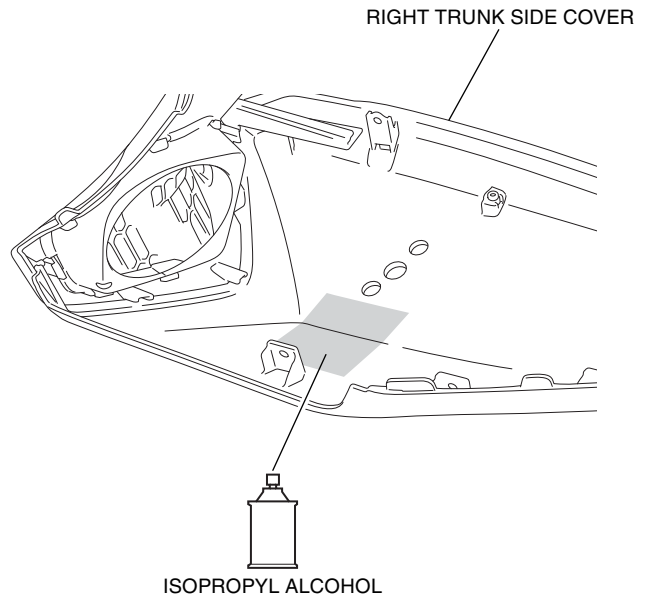

7. Route the CB antenna cord as shown.

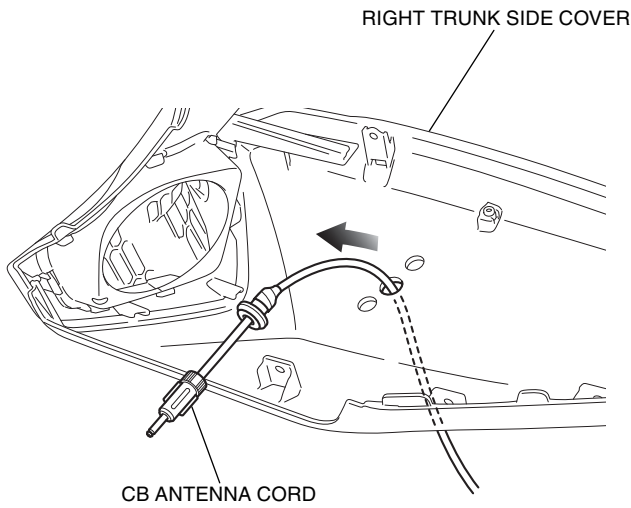

8. Attach the cushions as shown.

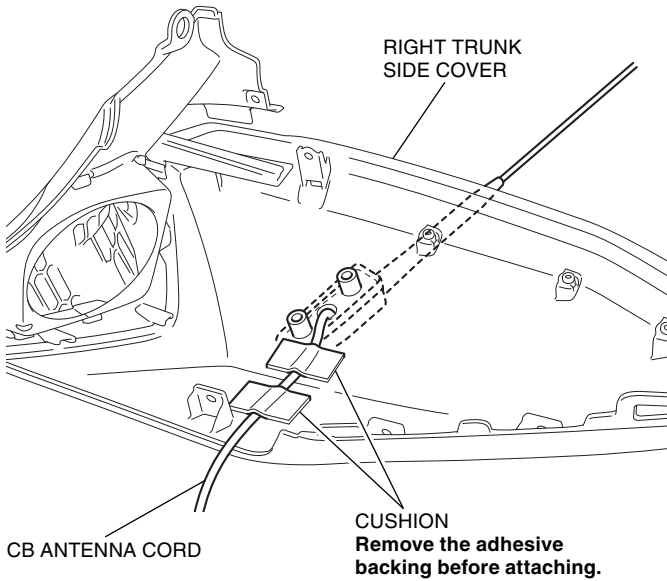

9. Route and secure the CB antenna cord as shown.
<Right side>

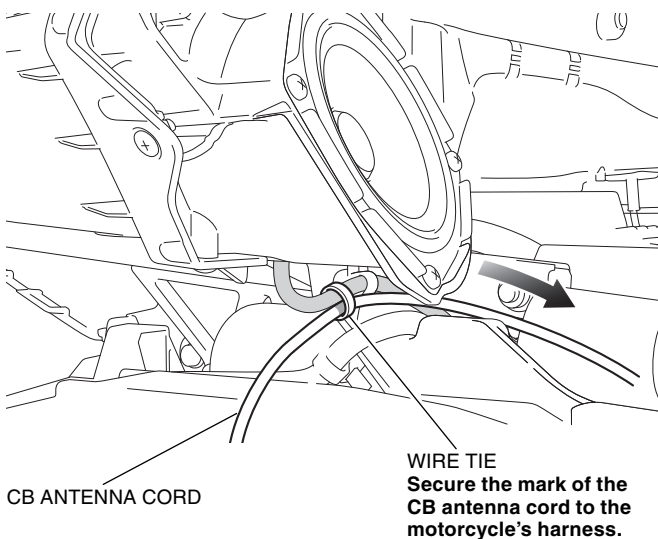

10. Route the CB antenna cord as shown.

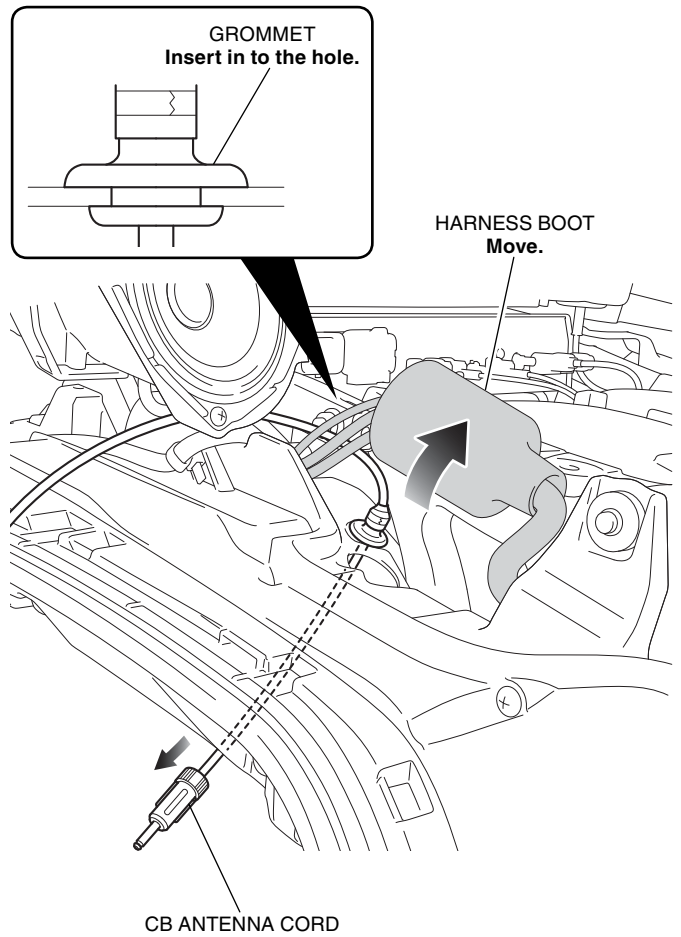

11. Install the right saddlebag upper cover and right trunk side cover in the reverse order of removal.

12. Install the CB antenna stay as shown.

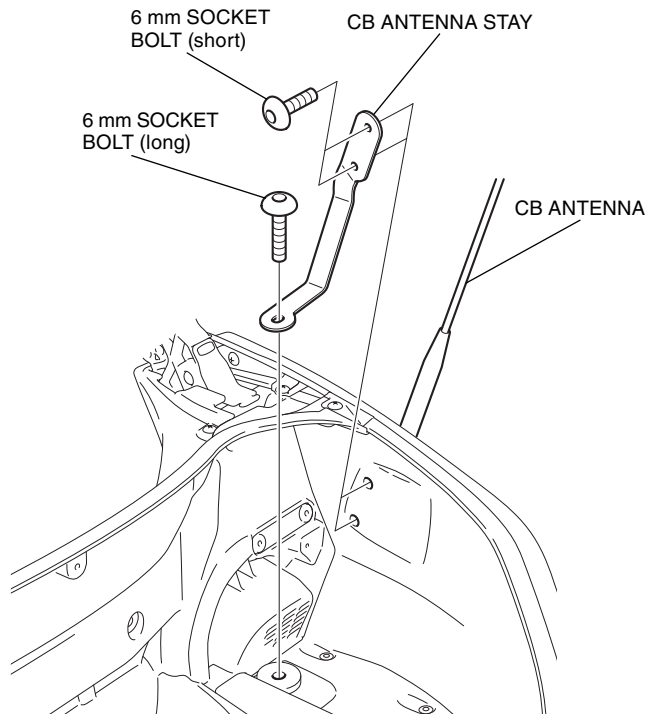

13. Connect the CB antenna cord as shown.

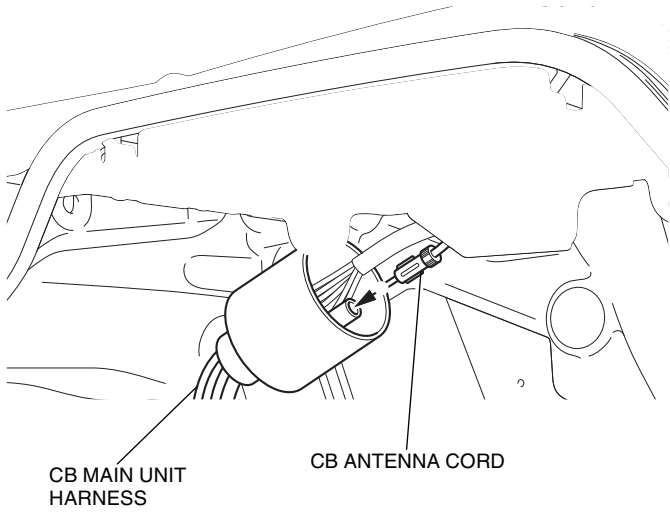

14. Perform Steps 25 to 35 on the CB Radio (sold separately) installation instructions.