

INSTALLATION INSTRUCTIONS

Accessory	Application	Publication No.
REAR SPEAKER ATTACHMENT KIT P/N 08B71-MKC-A00	GL1800B/BD GL1800/D/DA (go to page 10)	MII 16426
		Issue Date
		January 2018

Honda Dealer: Please give a copy of these instructions to your customer.

PARTS LIST

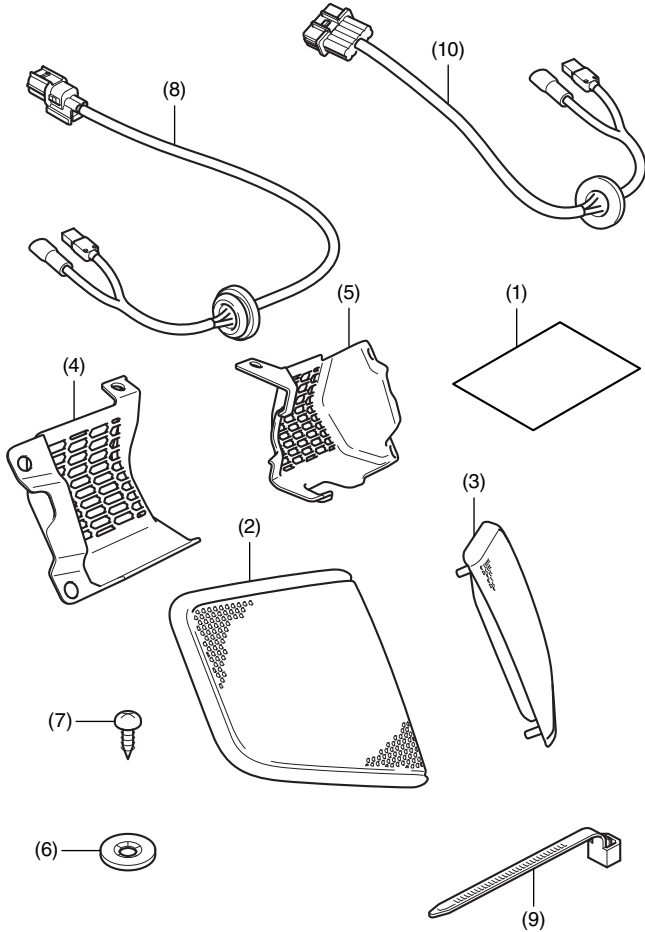

No.	Description	Qty
(1)	Installation Instructions URL	1
(2)	Speaker right grill	1
(3)	Speaker left grill	1
(4)	Speaker right cover	1
(5)	Speaker left cover	1
(6)	Speed nut	9
(7)	5 mm screw	7
(8)	Right sub harness	1
(9)	Wire tie	4
(10)	Left sub harness	1

REAR SPEAKER KIT

Sold separately

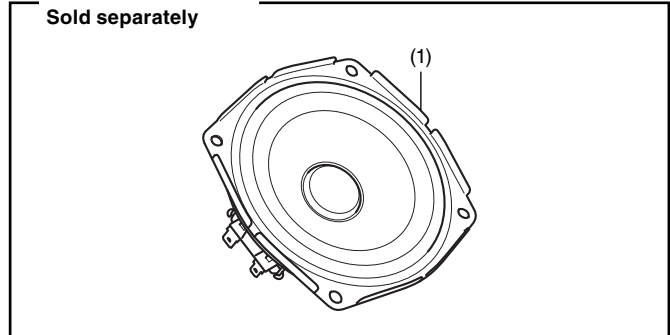

No.	Description	Qty
(1)	Speaker	2

TOOLS AND SUPPLIES REQUIRED

- Phillips screwdriver
- Snips
- Power drill
- Drill bit (4 and 10 mm)
- File
- Dish soap solution
(Water:Dish soap / 100:1)
- Shop towel
- Torque wrench

TORQUE CHART

Tighten all screws, bolts, and nuts to their specified torque values. Refer to the Service Manual for the torque values of the removed parts.

Item	N-m	kgf-m	lbf-ft
5 mm screw	4.2	0.4	3.1

INSTALLATION

NOTE:

- Disconnect the negative (-) cable from the battery before installing this accessory.
- The memory of the clock will be erased when you disconnect the battery. Reset the clock after reconnecting the battery.
- Reinstall the removed parts on the motorcycle and make sure that the wires and harnesses are not pinched.
- Trim the excess ends off the wire ties after attaching them to the wire harnesses. Do not allow the cut part of the wire tie to interfere with another harness or brake hose.

1. Open the left saddlebag lid as shown.

- Repeat on the right side.

<Left side>

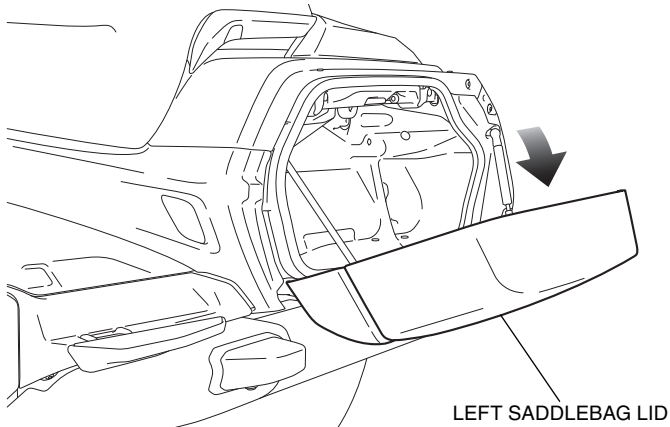

2. Remove the left side cover as shown, and disconnect the battery negative (-) cable.

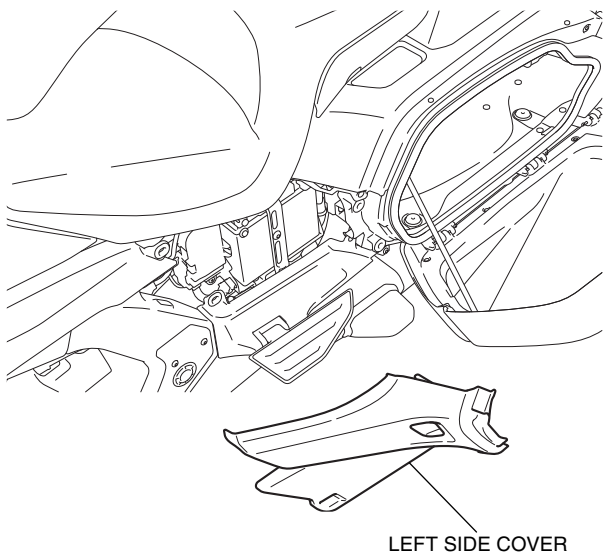

3. Remove the right side cover in the same manner as the left side.

4. Remove the seat as shown.

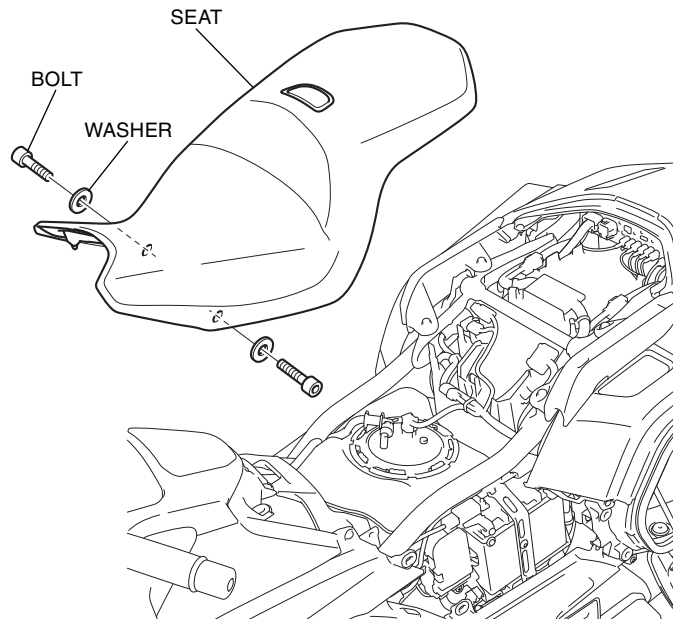

5. Remove the fuse holders as shown.

<Left side>

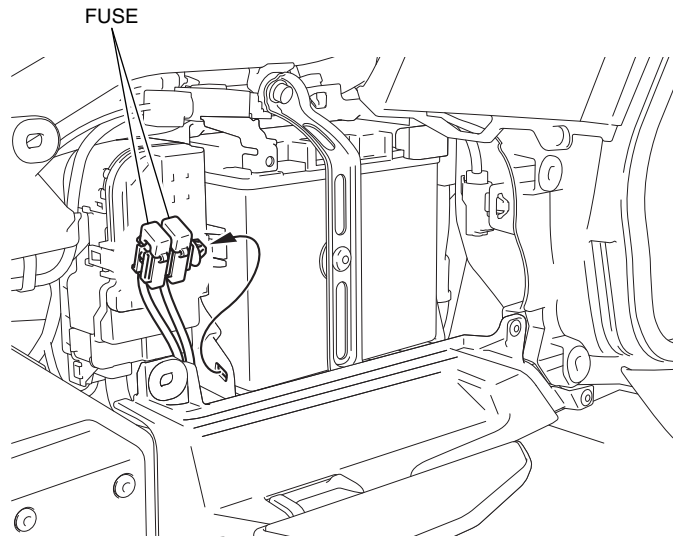

6. Remove the left pillion step holder cover as shown.
- Repeat on the right side.

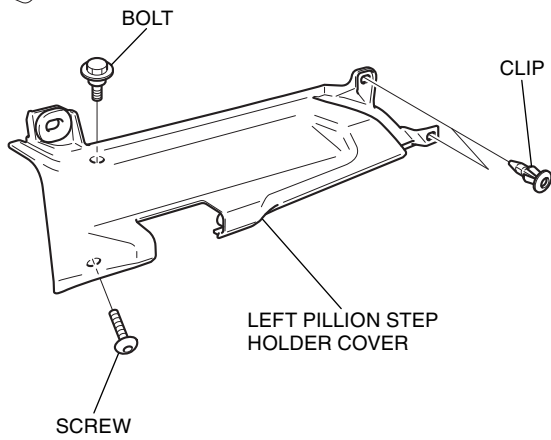
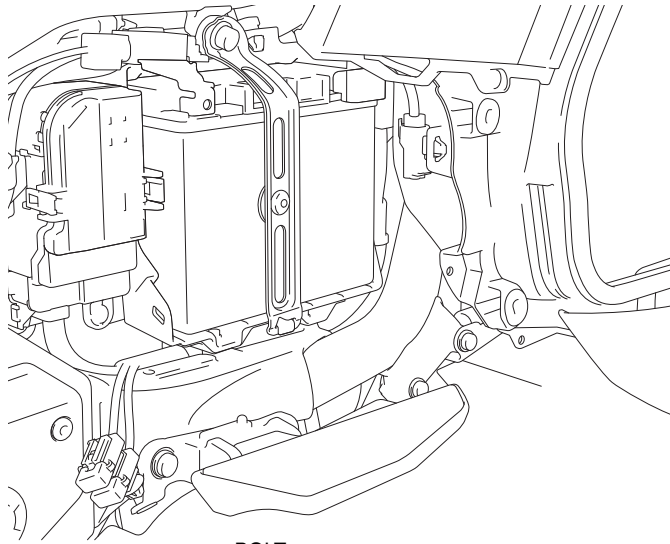

7. Remove the right and left rear top lid as shown.

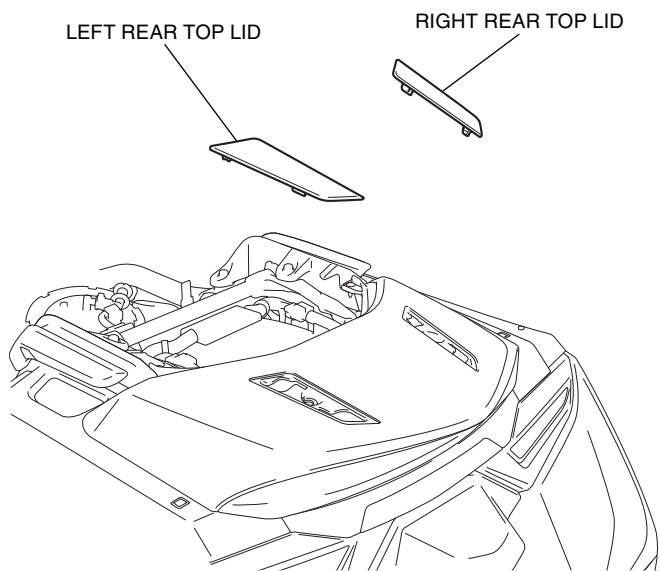

8. Remove the clips and screws as shown.

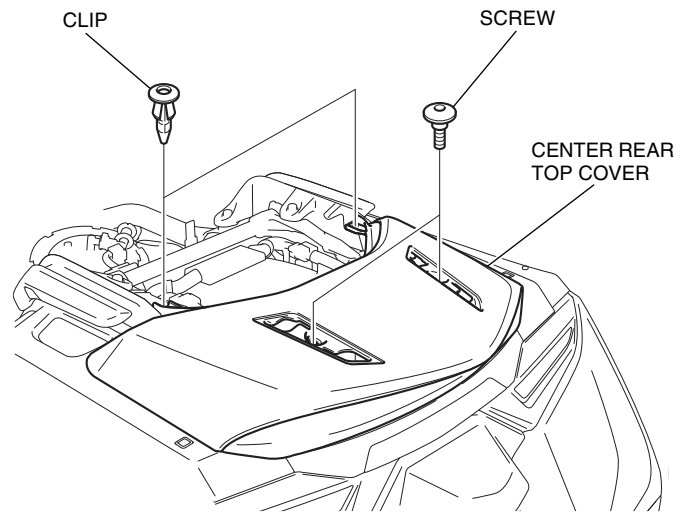

9. Remove the center rear top cover by pulling it firmly up and back as shown.

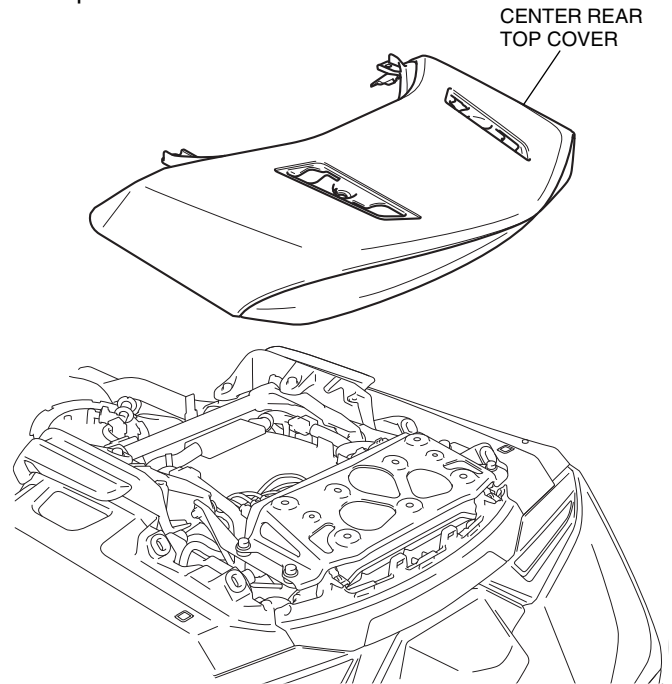

10. Remove the right and left passenger grips as shown.

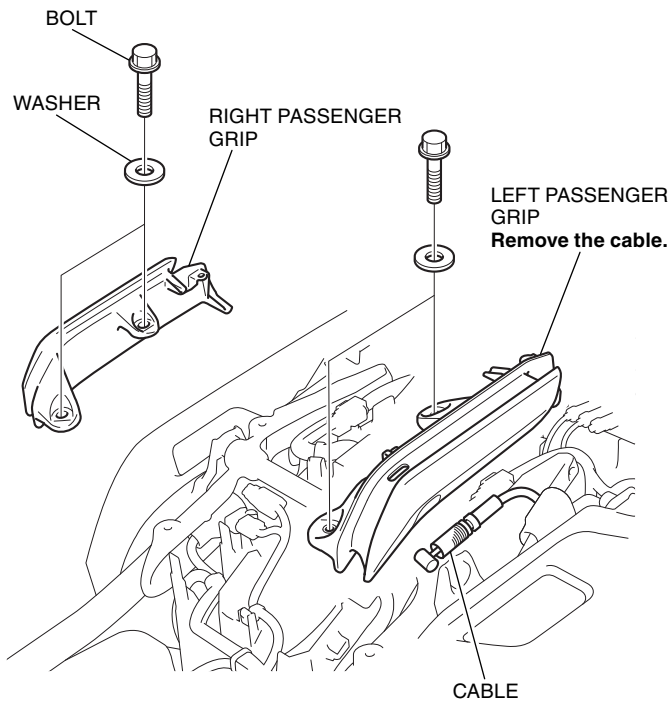

11. Remove the clips as shown.

- Repeat on the right side.

<Left side>

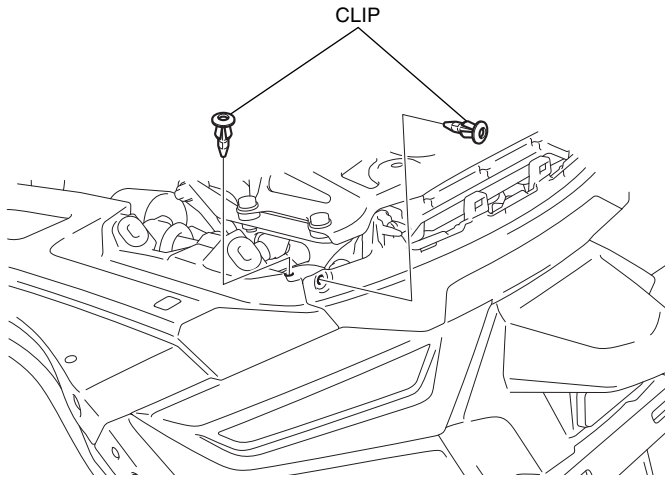

12. Remove the rear fender as shown.

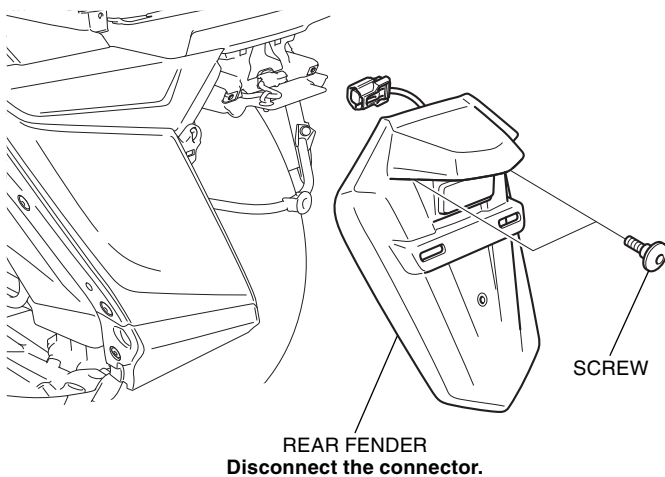

13. Remove the saddlebag rear center cowl as shown.

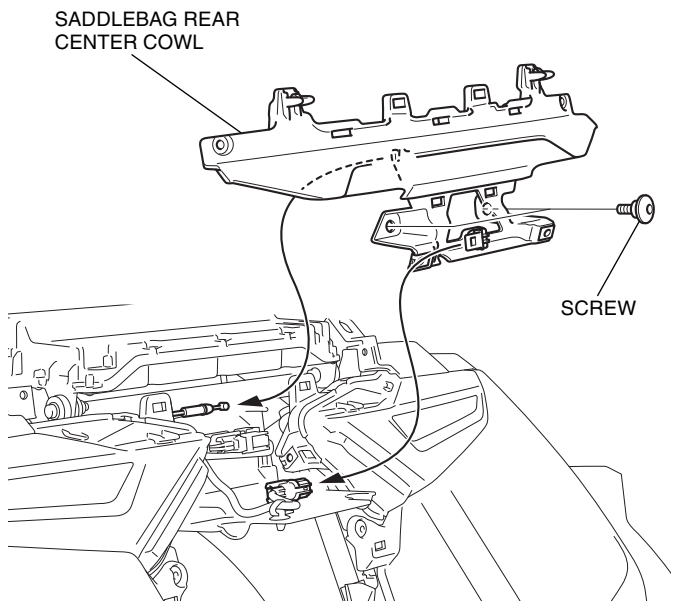

14. Remove the parts as shown.

- Repeat on the left side.

<Right side>

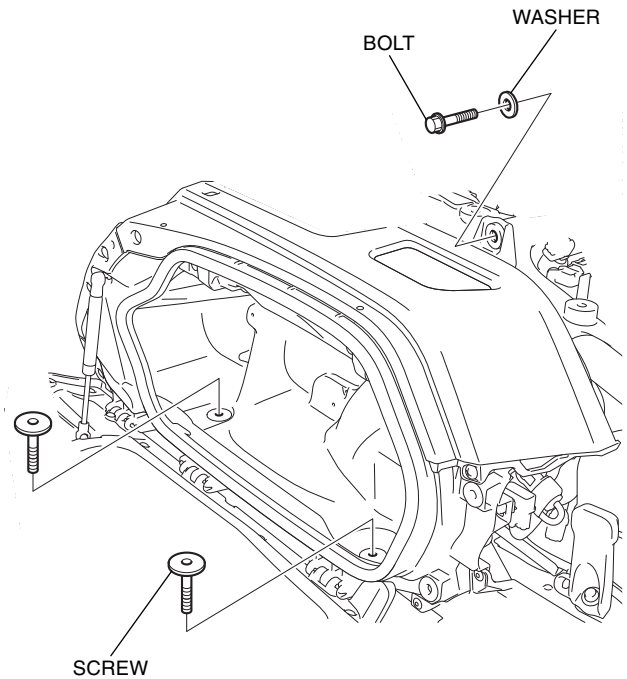

15. Remove the screw as shown.

- Repeat on the left side.

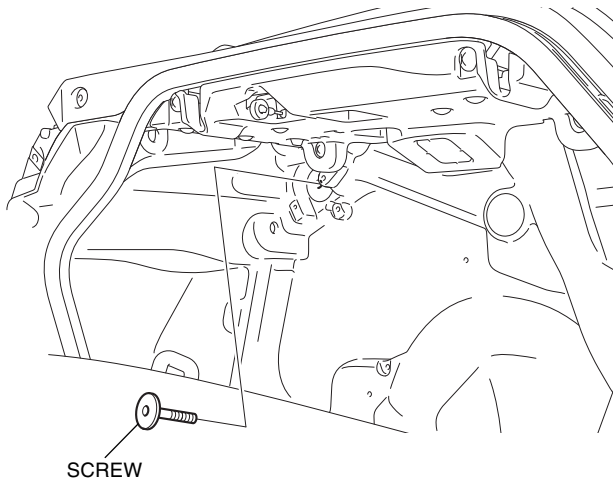

16. Remove the right saddlebag upper cover as shown.

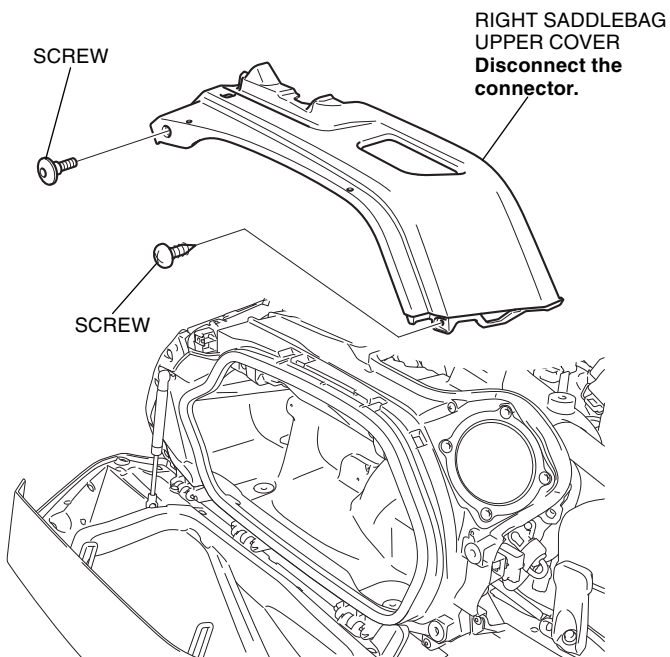

17. Remove the speaker cover as shown.

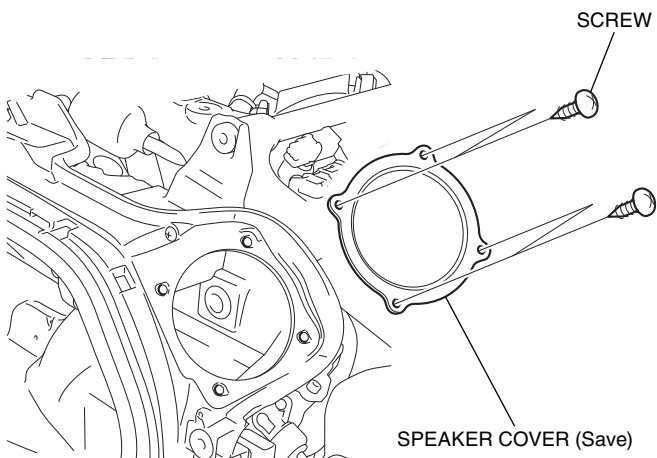

18. Remove the left saddlebag upper cover and speaker cover in the same manner as the right side.

19. Drill a 4 mm hole at each marked point of the right saddlebag upper cover as shown.

- Remove the any burrs from the edge of the hole.

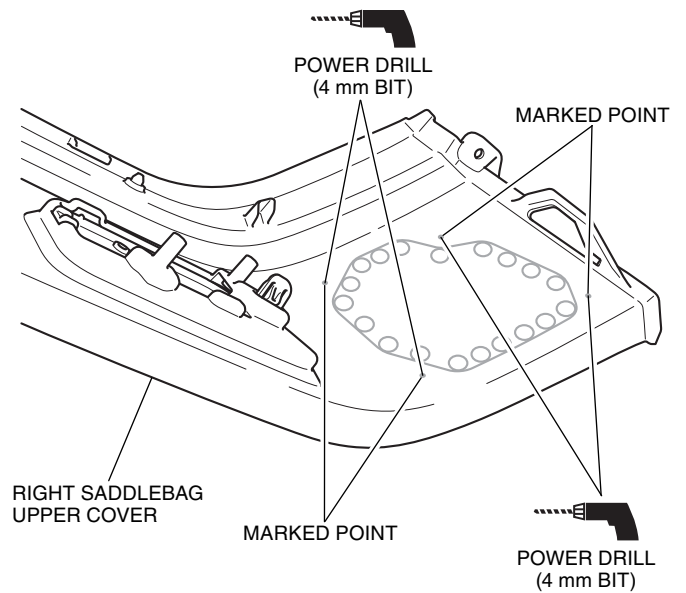

20. Drill 10 mm holes the marked lines of the right saddlebag upper cover as shown.

- Drill holes at the center of the marked lines.

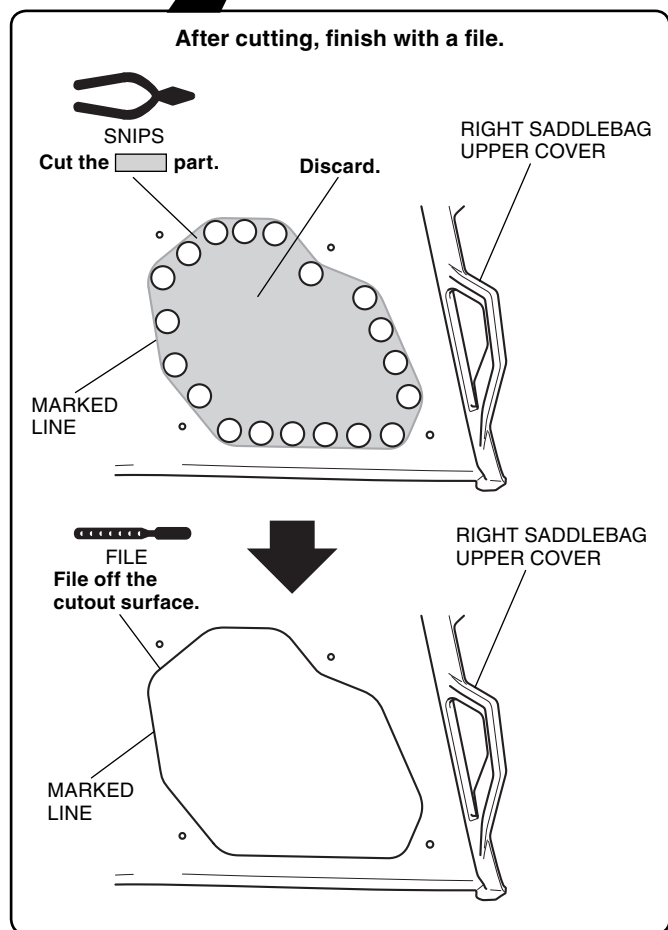
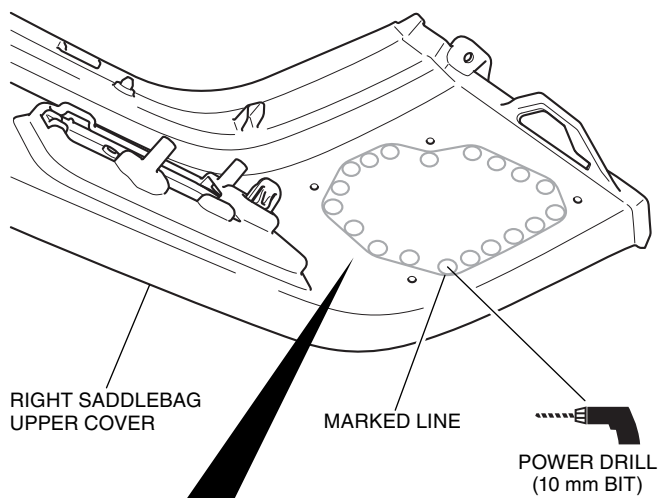

21. Cut the left saddlebag upper cover in the same manner as the right side.

22. Install the right speaker grill as shown.

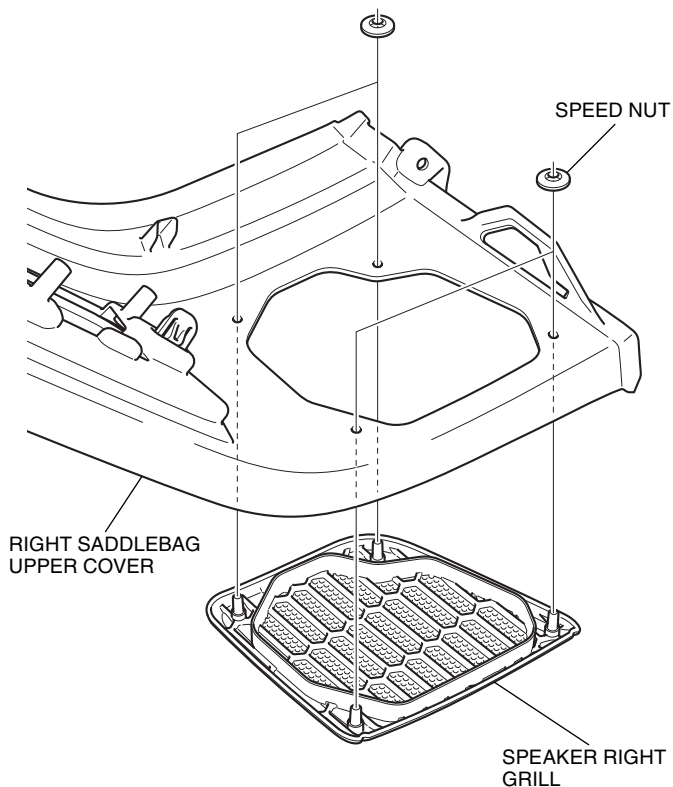

23. Install the speaker left grill in the same manner as the right side.

24. Remove the plug as shown.

- Repeat on the left side.

<Right side>

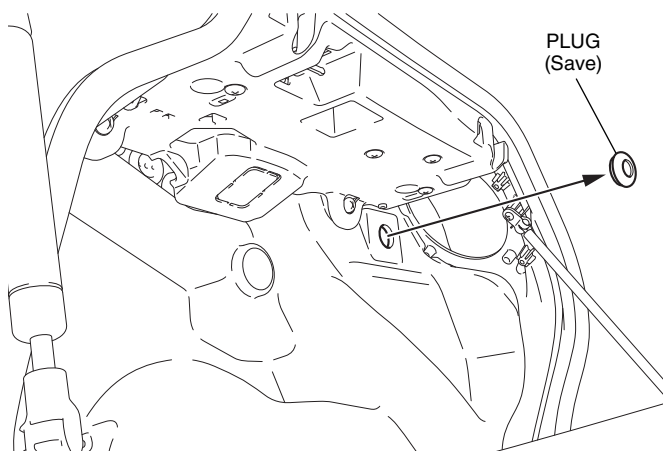

25. Apply dish soap solution to the position shown.

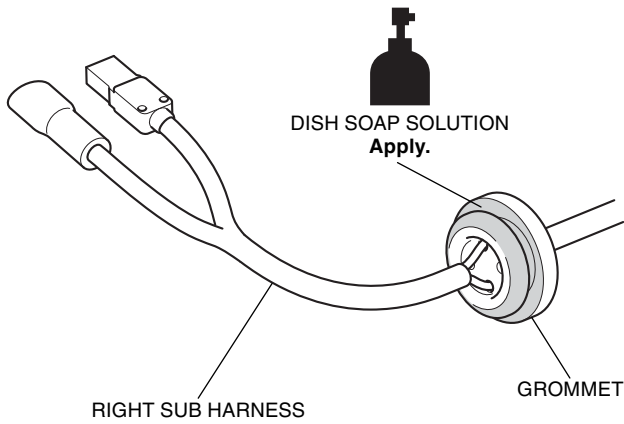

26. Move the right saddlebag and route the right sub harness as shown.

- Repeat on the left side.

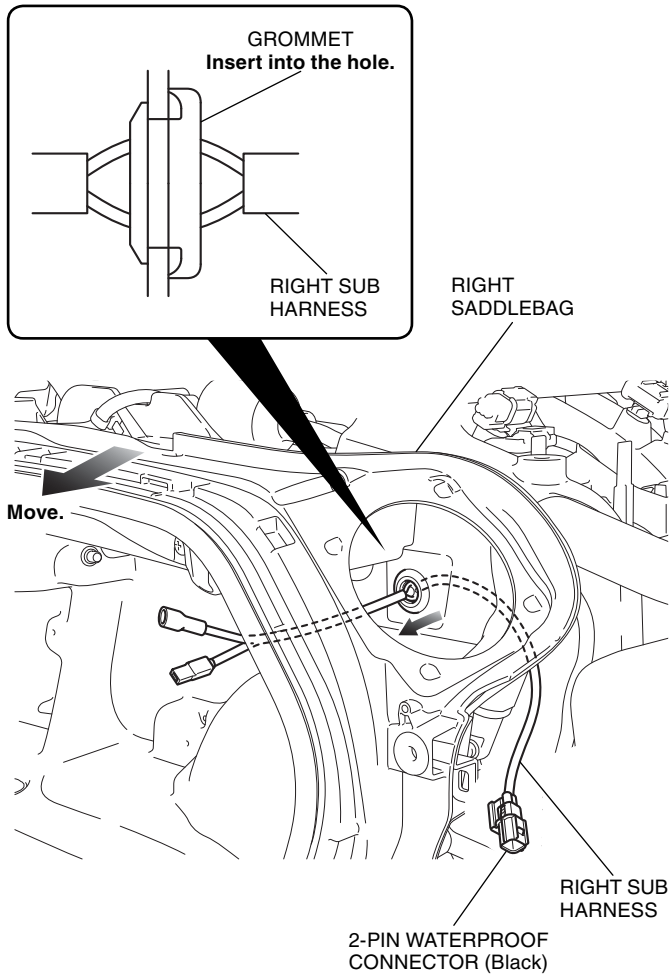

27. Route the right sub harness as shown.

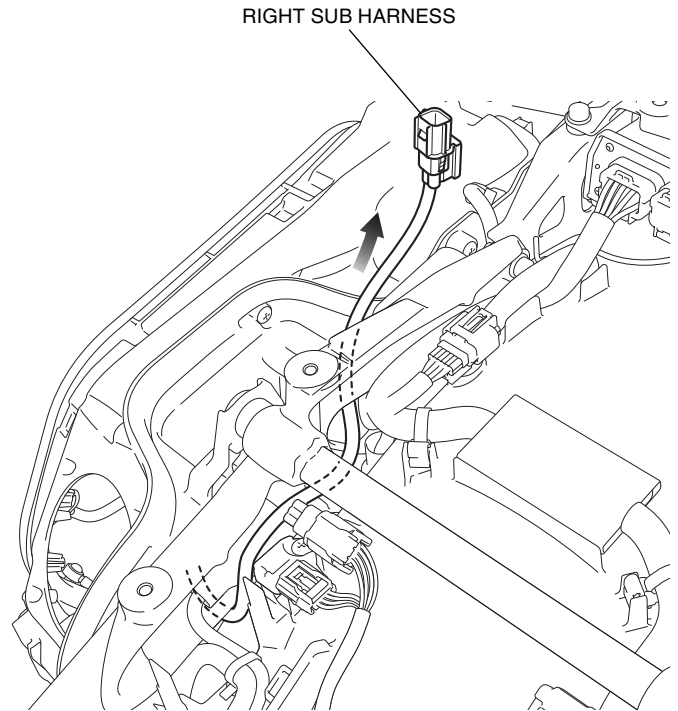

28. Install the right saddlebag in the reverse order of removal.

29. Remove the dummy connector as shown.

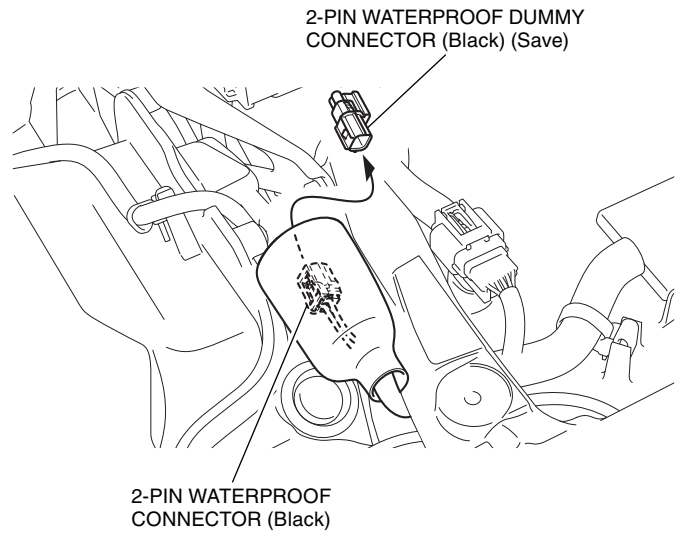

30. Connect the right sub harness as shown.

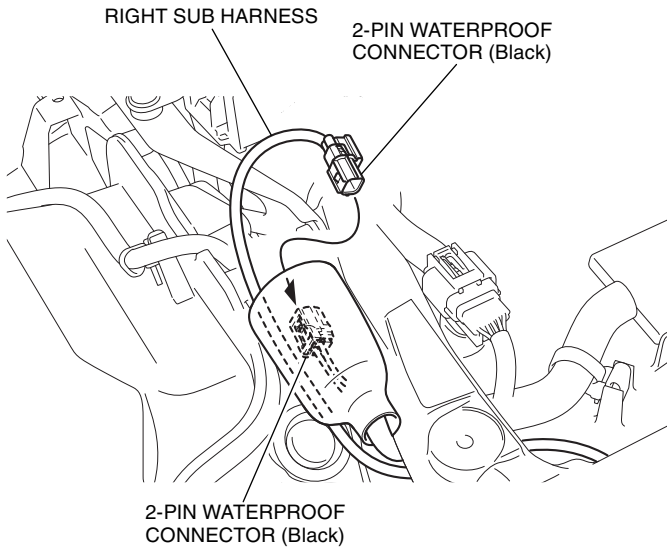

31. Secure the right sub harness with the wire ties as shown.

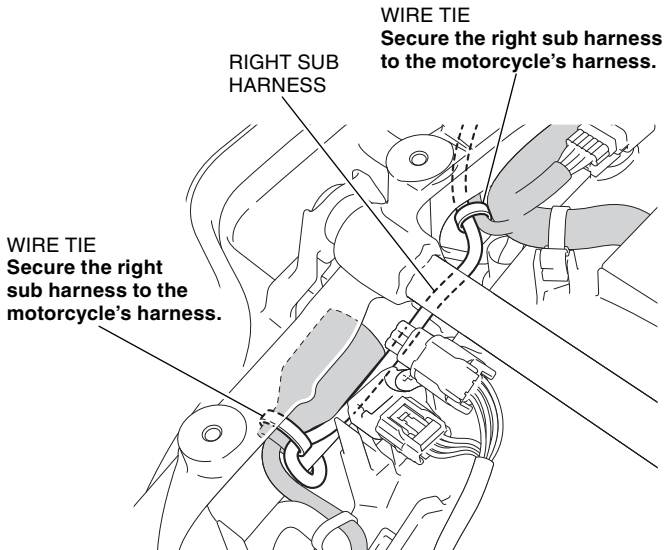

32. Route the left sub harness as shown.

<Left side>

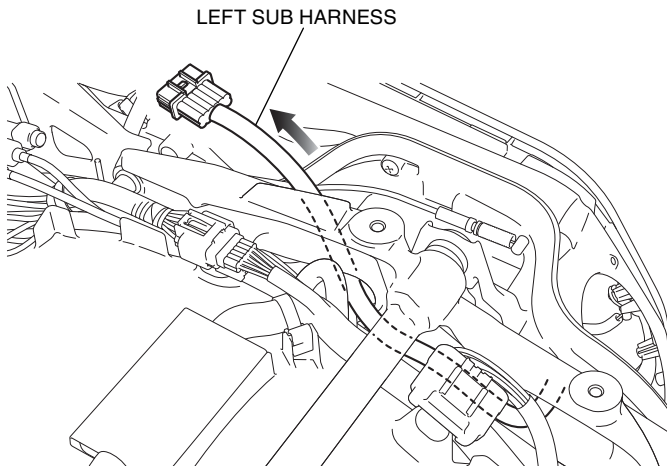

33. Install the left saddlebag in the reverse order of removal.

34. Remove the dummy connector as shown.

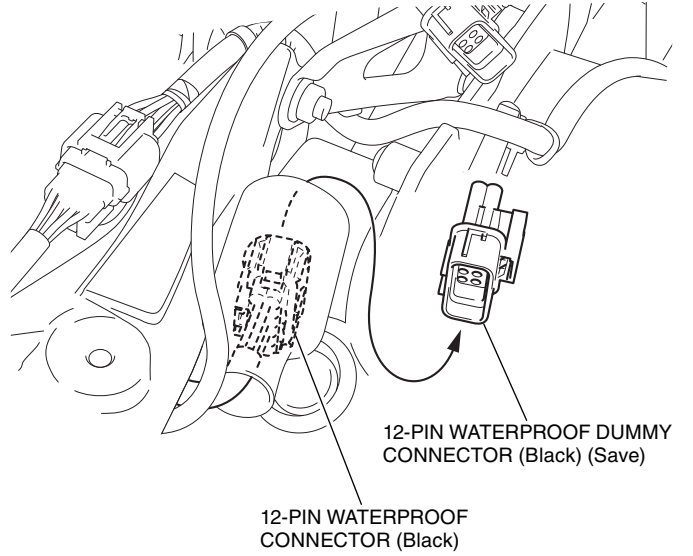

35. Connect the left sub harness as shown.

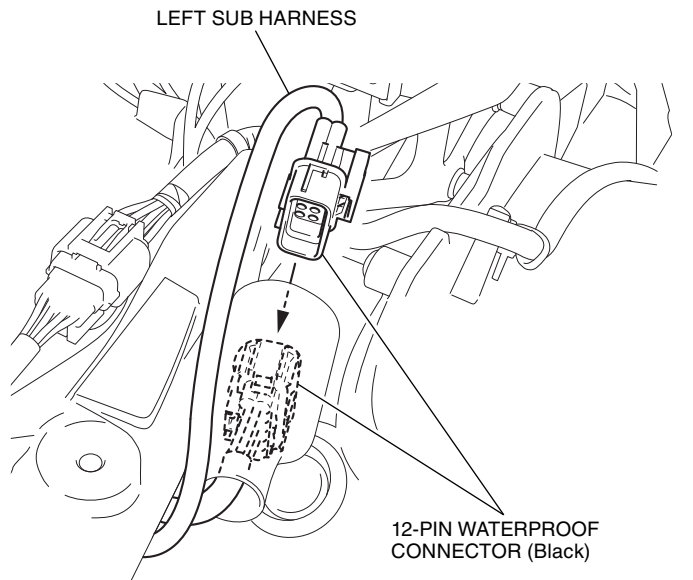

36. Secure the left sub harness with the wire tie as shown.

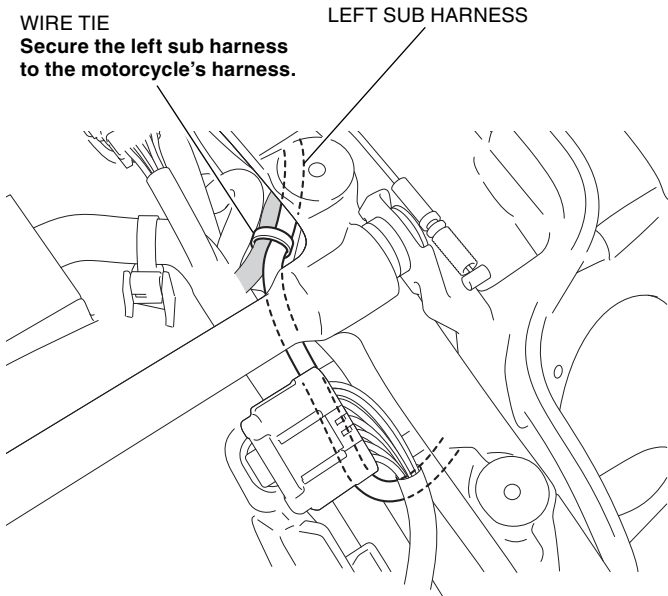

37. Install the accessory speaker as shown.

<Right side>

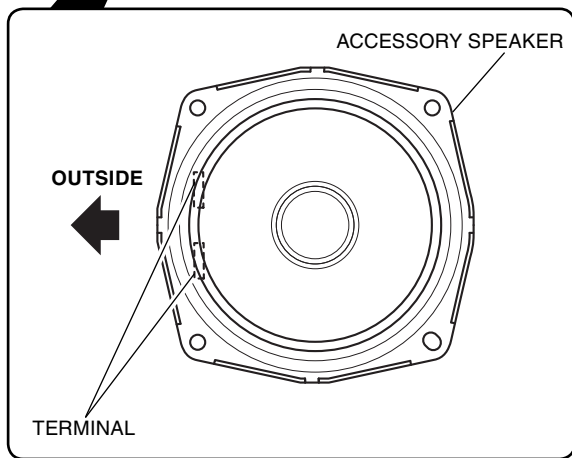
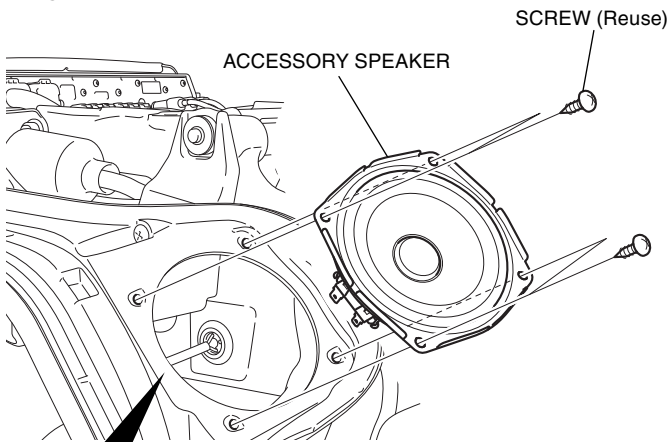

38. Connect the right sub harness as shown.

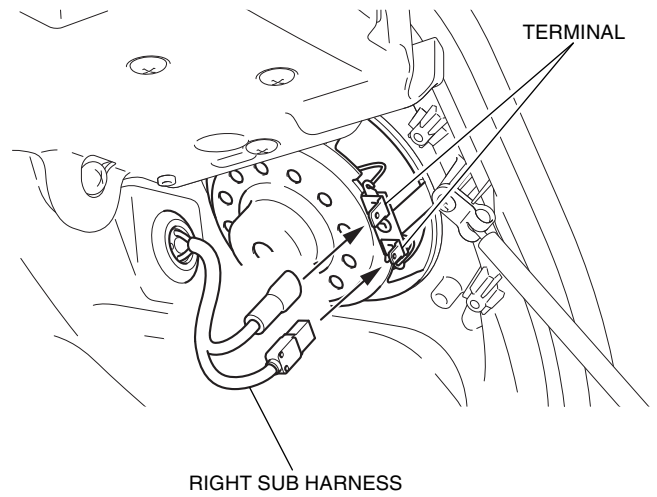

39. Install the right speaker cover as shown.

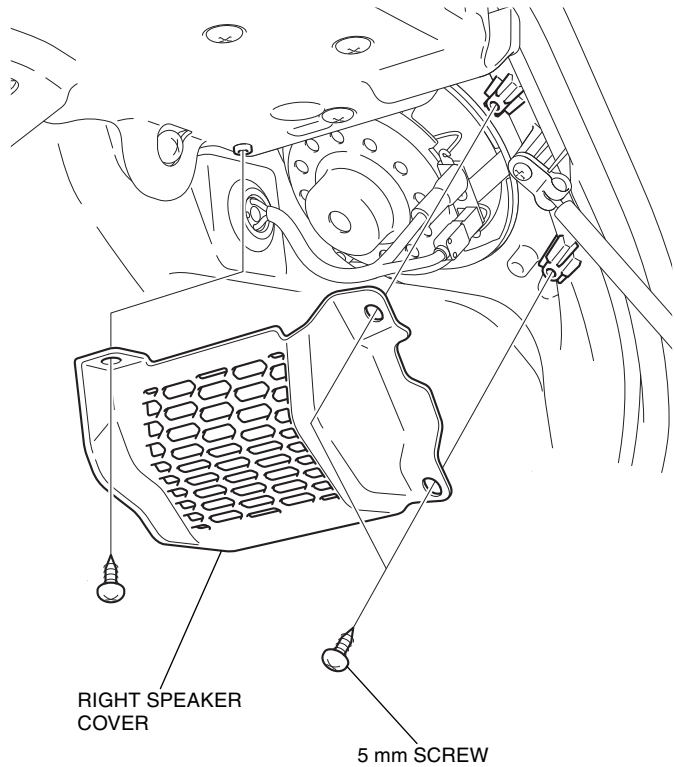

40. Install the left side speaker and left speaker cover in the same manner as the right side.

41. Install the motorcycle's parts in the reverse order of removal.

- Confirm that any wire harness is not caught or too tight.

42. Check the speaker, headlight and the other lights for proper operation.

INSTALLATION INSTRUCTIONS

Accessory	Application	Publication No.
REAR SPEAKER ATTACHMENT KIT P/N 08B71-MKC-A00	GL1800/D/DA (With trunk removal kit)	MII 16426
		Issue Date
		January 2018

Honda Dealer: Please give a copy of these instructions to your customer.

PARTS LIST

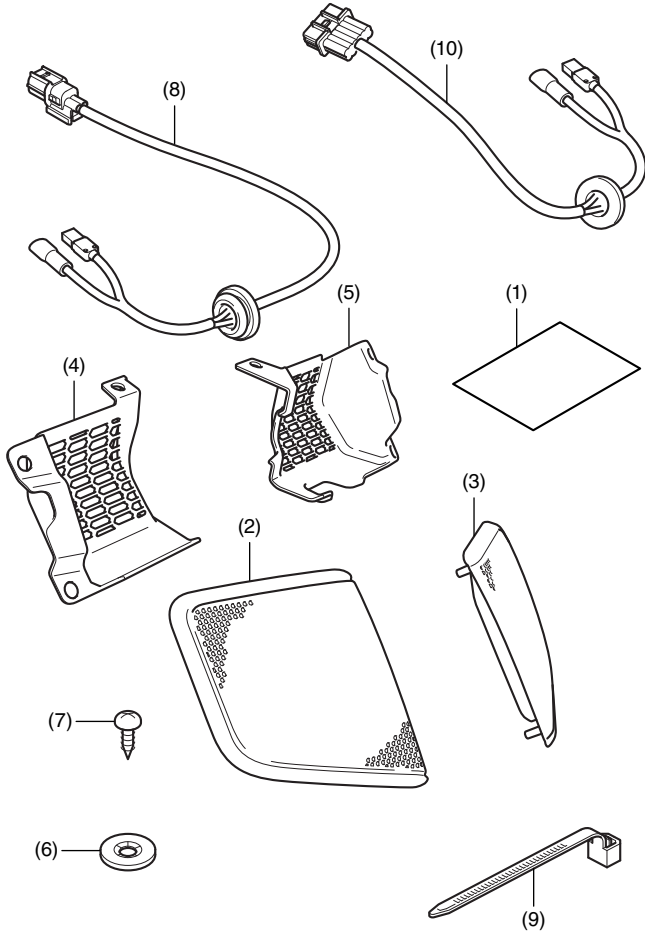

No.	Description	Qty
(1)	Installation Instructions URL	1
(2)	Speaker right grill	1
(3)	Speaker left grill	1
(4)	Speaker right cover	1
(5)	Speaker left cover	1
(6)	Speed nut	9
(7)	5 mm screw	7
(8)	Right sub harness	1
(9)	Wire tie	4
(10)	Left sub harness	1

REAR SPEAKER KIT Sold separately

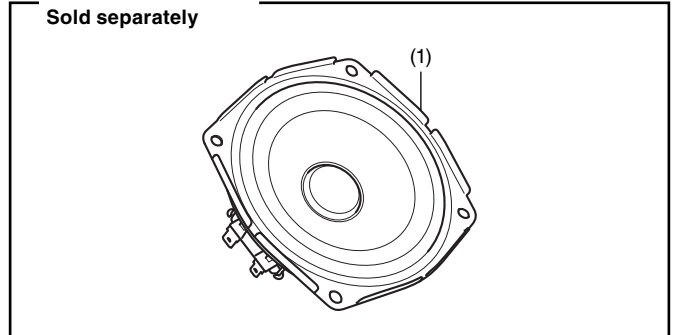

No.	Description	Qty
(1)	Speaker	2

5 mm SCREW Sold separately

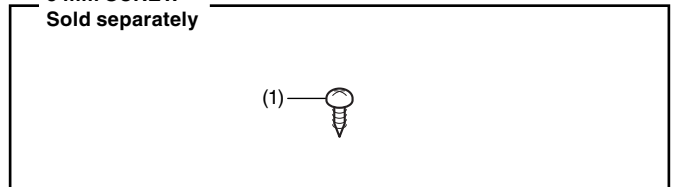

No.	Description	Qty
(1)	5 mm screw	8

TOOLS AND SUPPLIES REQUIRED

- Phillips screwdriver
- Snips
- Powers drill
- Drill bit (4 and 10 mm)
- File
- Dish soap solution
(Water:Dish soap / 100:1)
- Shop towel
- Torque wrench

TORQUE CHART

Tighten all screws, bolts, and nuts to their specified torque values. Refer to the Service Manual for the torque values of the removed parts.

Item	N.m	kgf.m	lbf-ft
5 mm screw	4.2	0.4	3.1

INSTALLATION

NOTE:

- Disconnect the negative (-) cable from the battery before installing this accessory.
- The memory of the clock will be erased when you disconnect the battery. Reset the clock after reconnecting the battery.
- Reinstall the removed parts on the motorcycle and make sure that the wires and harnesses are not pinched.
- Trim the excess ends off the wire ties after attaching them to the wire harnesses. Do not allow the cut part of the wire tie to interfere with another harness or brake hose.

1. Open the left saddlebag lid as shown.

<Left side>

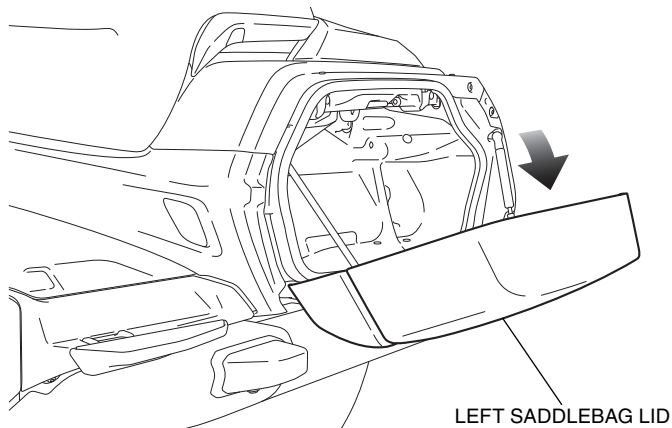

2. Remove the left side cover as shown, and disconnect the battery negative (-) cable.

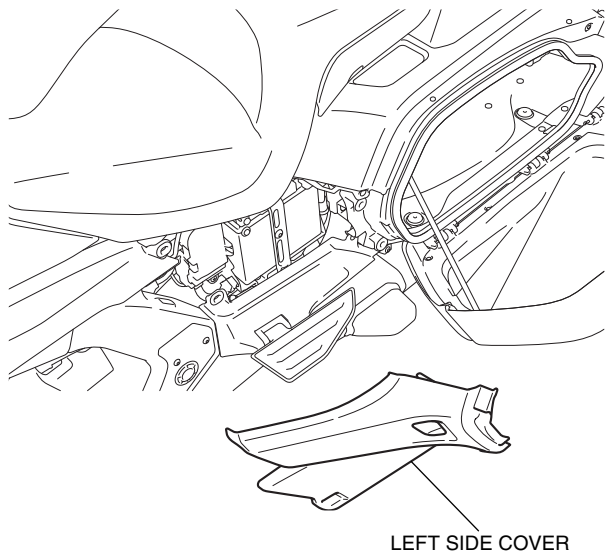

3. Remove the right side cover in the same manner as the left side.
4. Remove the seat as shown.

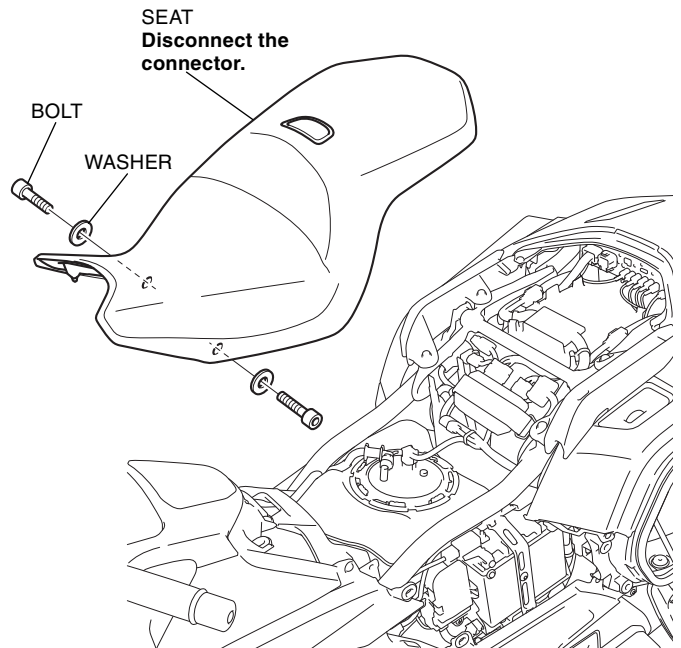

5. Remove the fuse holders as shown.

<Left side>

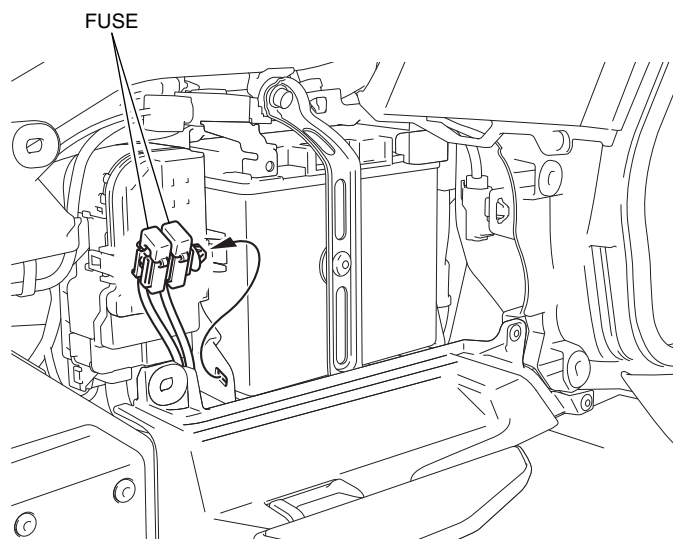

6. Remove the left pillion step holder cover as shown.
- Repeat on the right side.

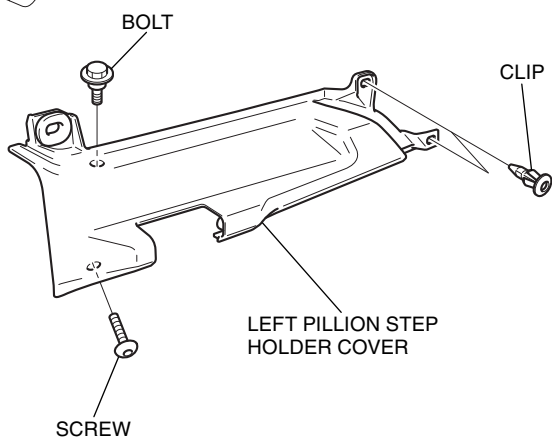
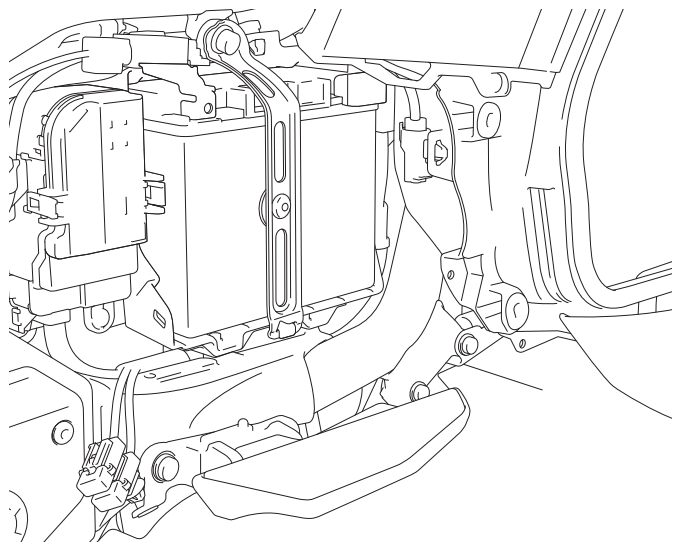

7. Remove the right and left rear top lid as shown.

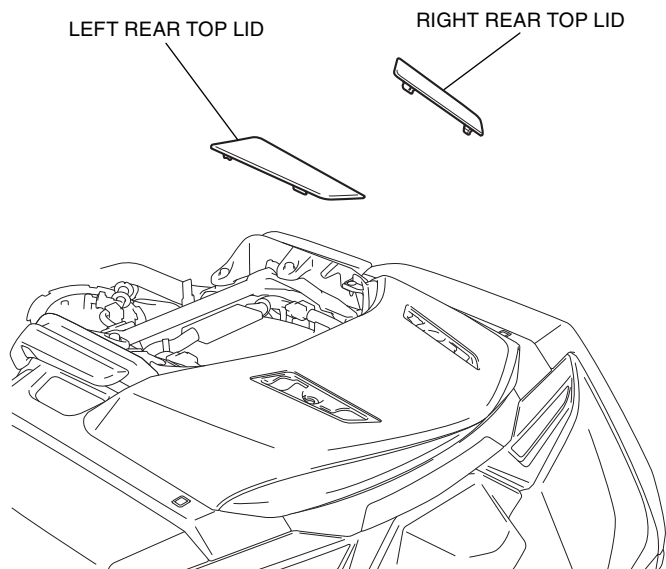

8. Remove the clips and screws as shown.

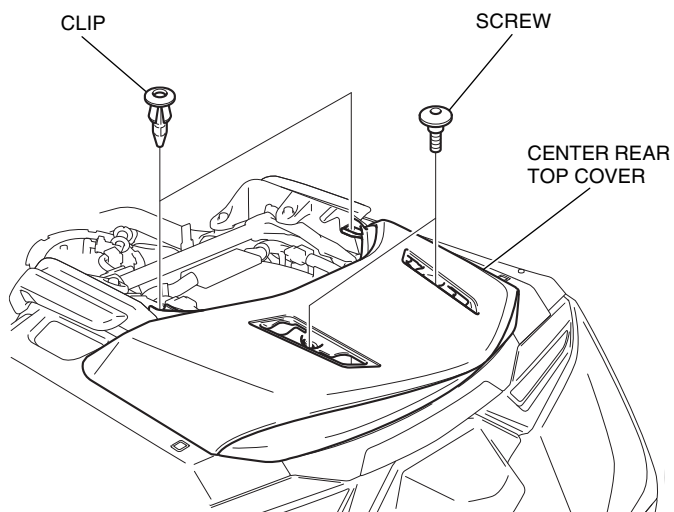

9. Remove the center rear top cover by pulling it firmly back and up as shown.

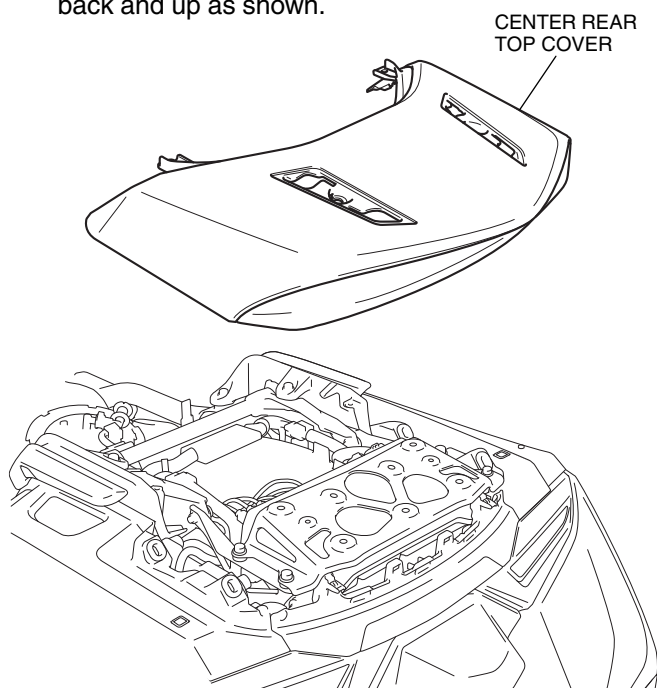

10. Remove the right and left passenger grips as shown.

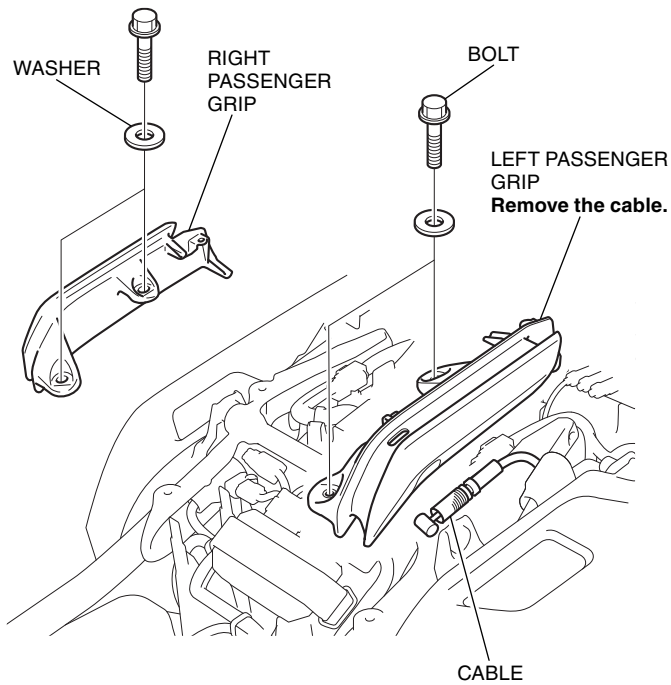

11. Remove the clips as shown.

- Repeat on the right side.

<Left side>

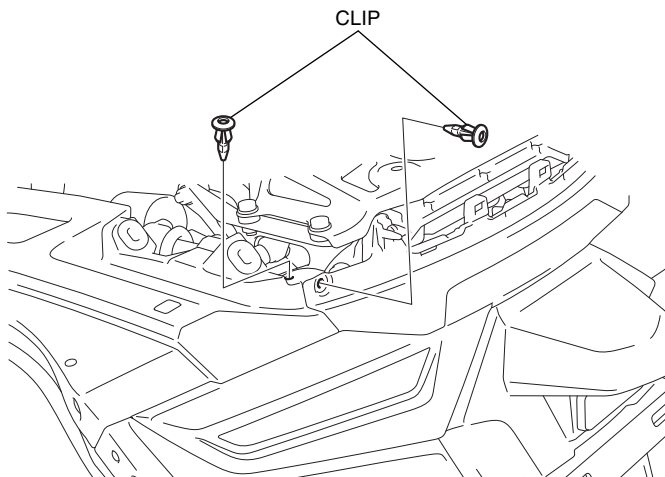

12. Remove the rear fender as shown.

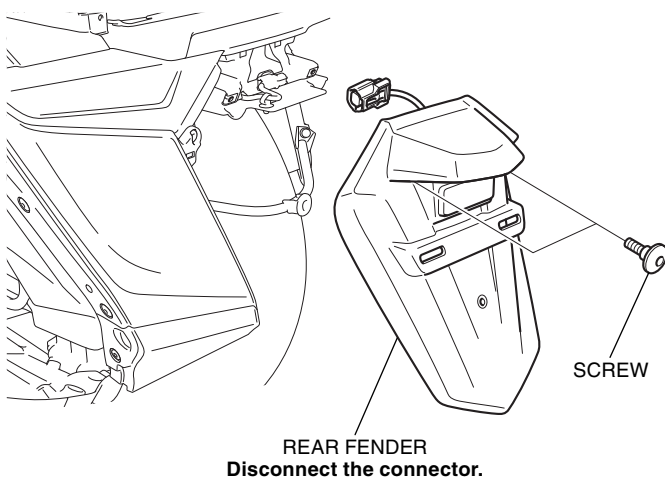

13. Remove the saddlebag rear center cowl as shown.

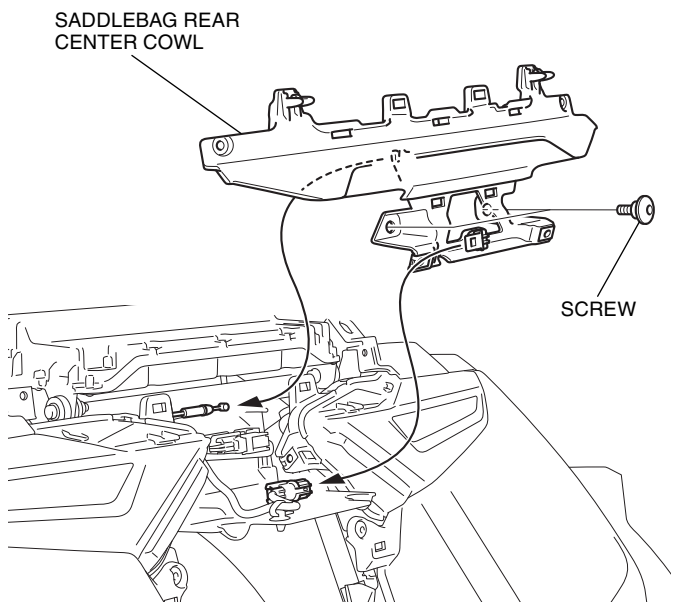

14. Remove the parts as shown.

- Repeat on the left side.

<Right side>

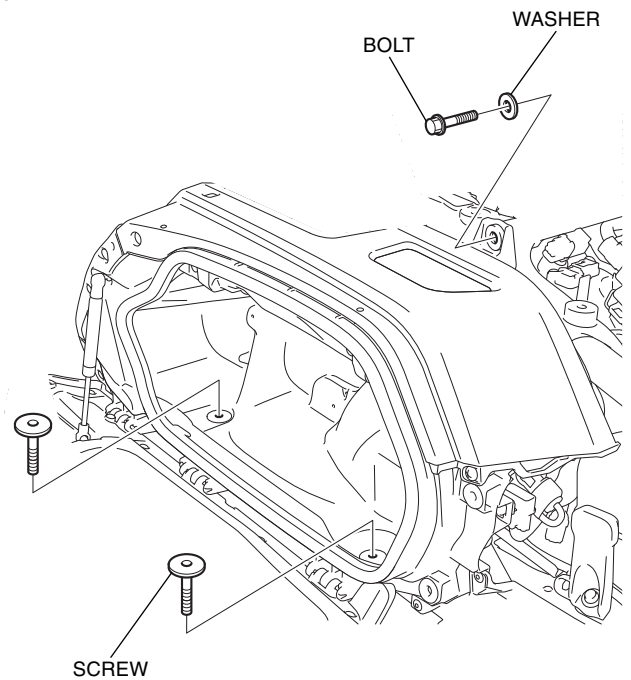

15. Remove the screw as shown.

- Repeat on the left side.

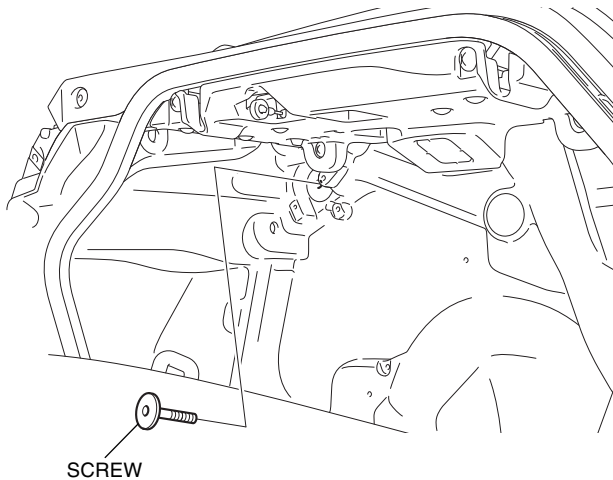

16. Remove the right saddlebag upper cover as shown.

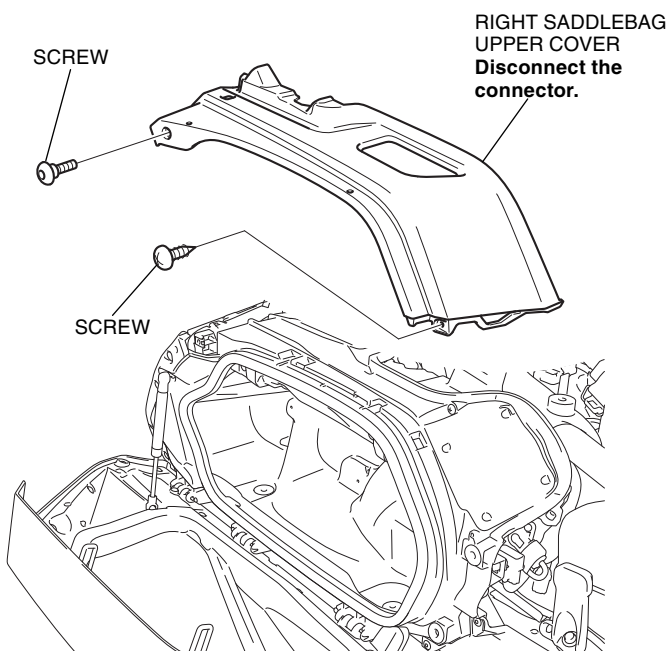

17. Drill 10 mm holes inside the marked line of the right saddlebag as shown.

- Remove the any burrs from the edge of the hole.

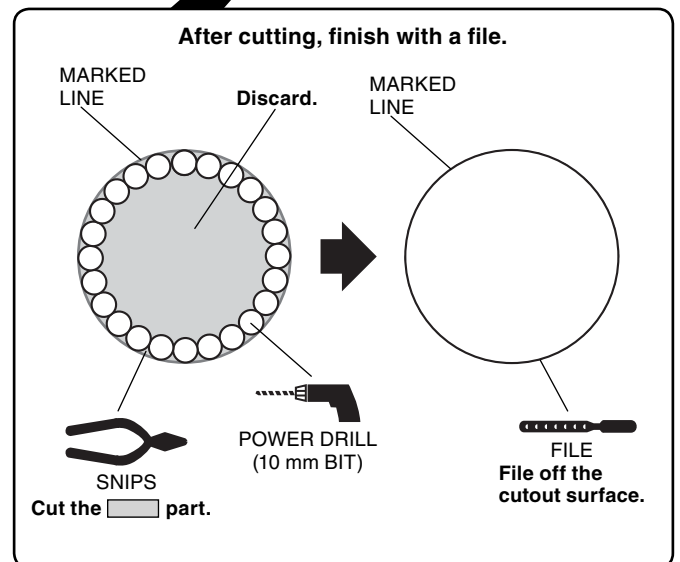
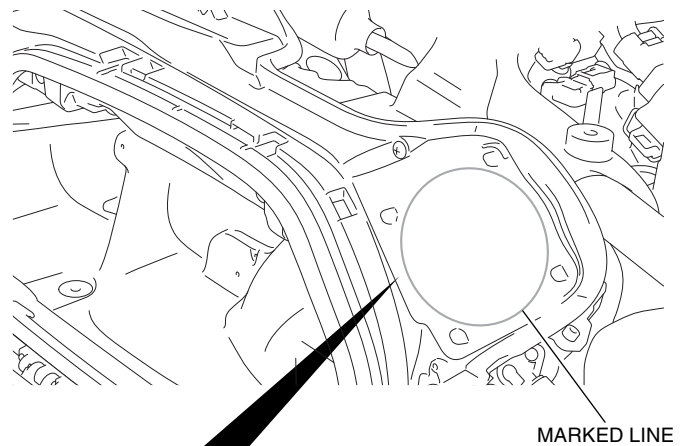

18. Arrange the accessory rear speaker as shown and confirm that there is no interference with the drilled hole.

- If there is interference, use a file to correct it.

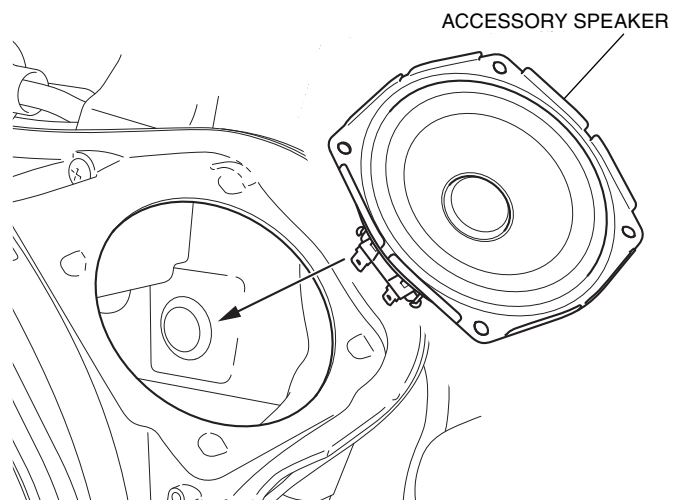

19. Drill a 4 mm hole at each marked point of the right saddlebag upper cover as shown.

- Remove the any burrs from the edge of the hole.

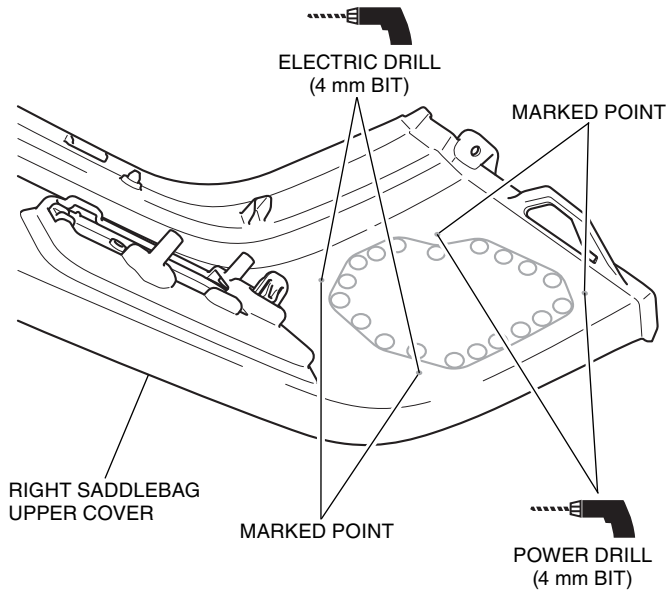

20. Drill 10 mm holes at the marked lines of the right saddlebag upper cover as shown.

- Drill holes at the center of the marked lines.

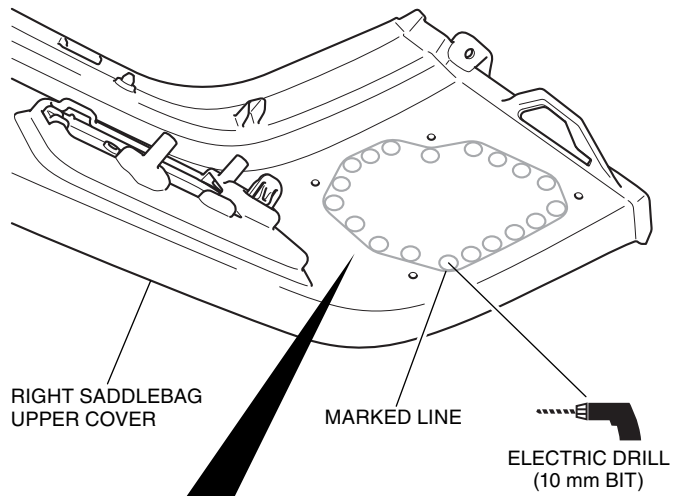

After cutting, finish with a file.

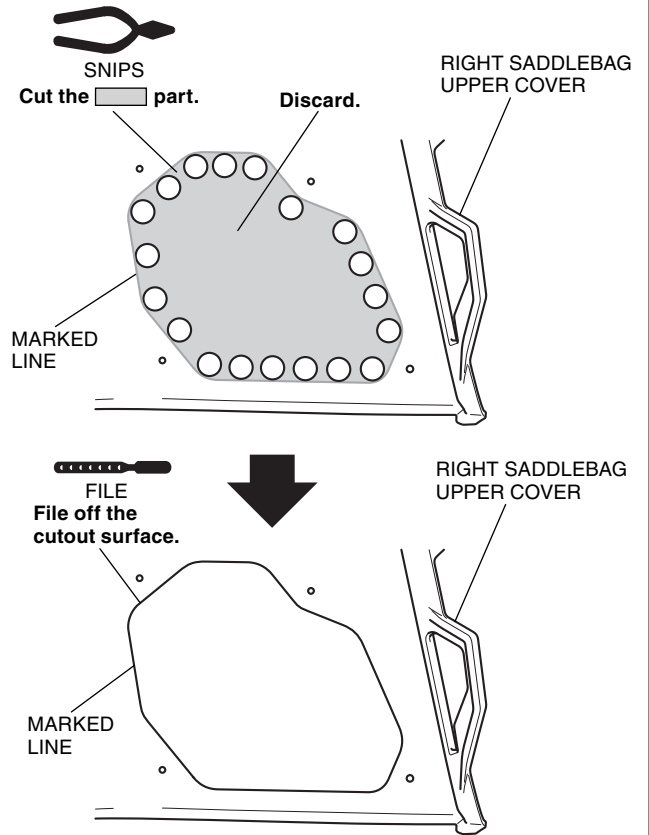

21. Remove the left saddlebag upper cover in the same manner as the right side.

22. Cut the left saddlebag and left saddlebag upper cover in the same manner as the right side.

23. Install the accessory speaker right grill as shown.

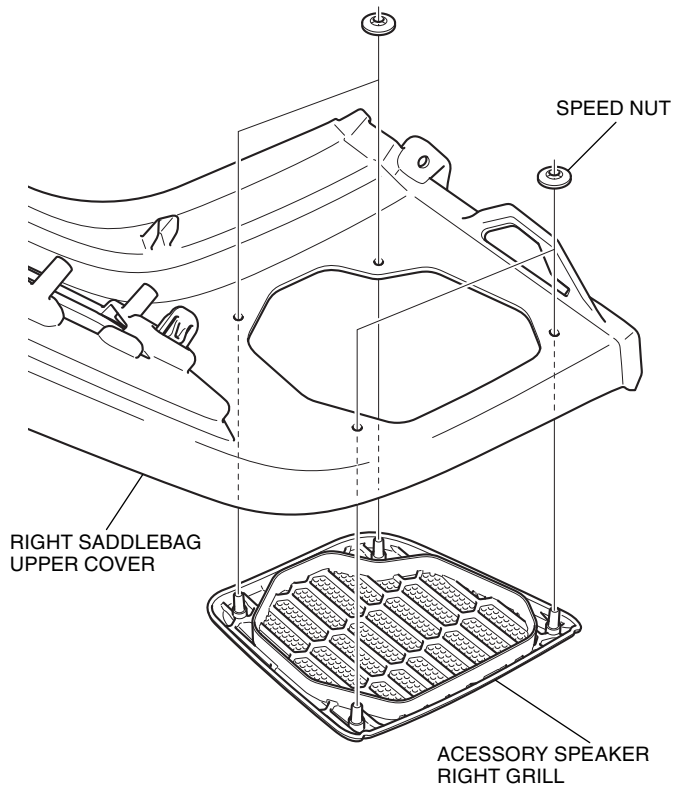

24. Install the accessory speaker left grill in the same manner as the right side.

25. Remove the plug as shown.

- Repeat on the left side.

<Right side>

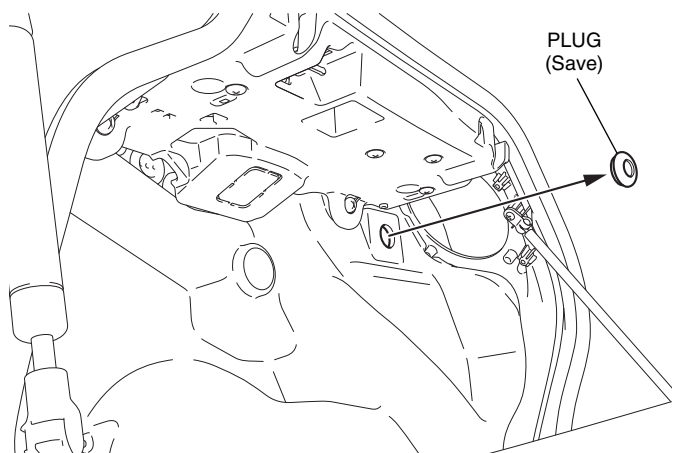

26. Apply dish soap solution to the position shown.

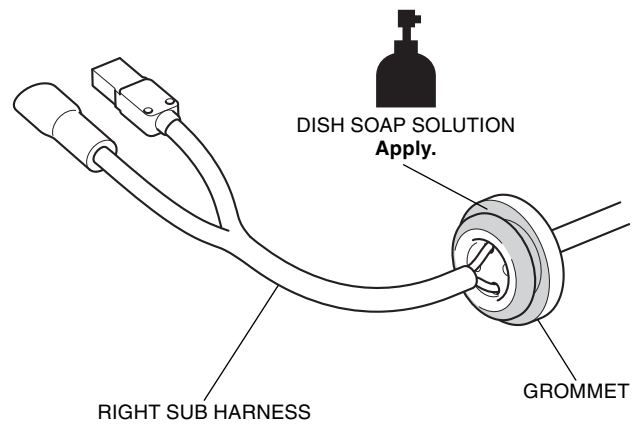

27. Move the right saddlebag and route the right sub harness as shown.

- Repeat on the left side.

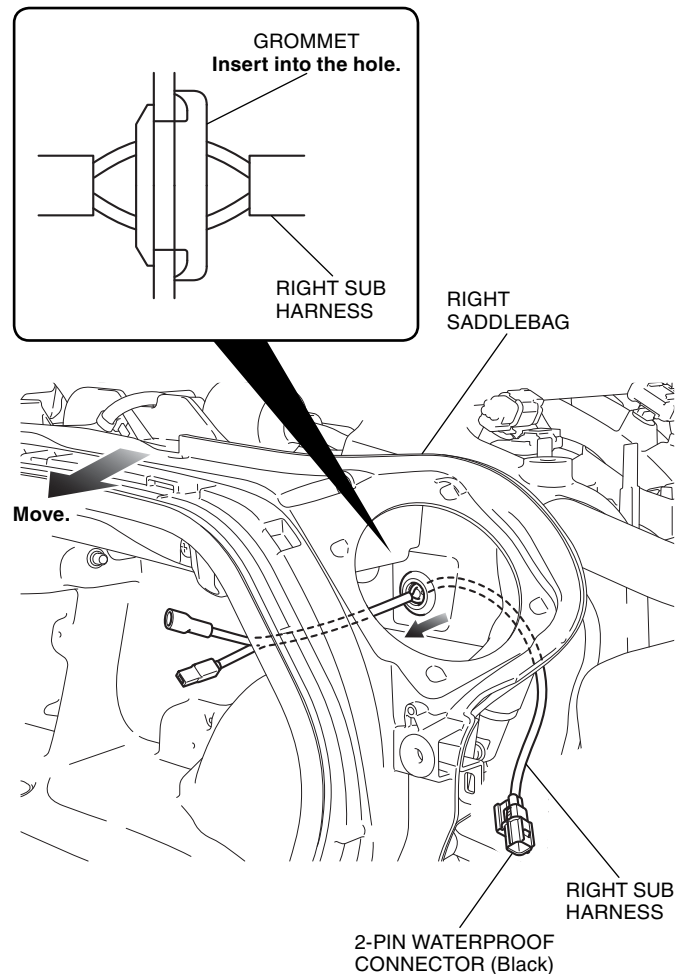

28. Route the right sub harness as shown.

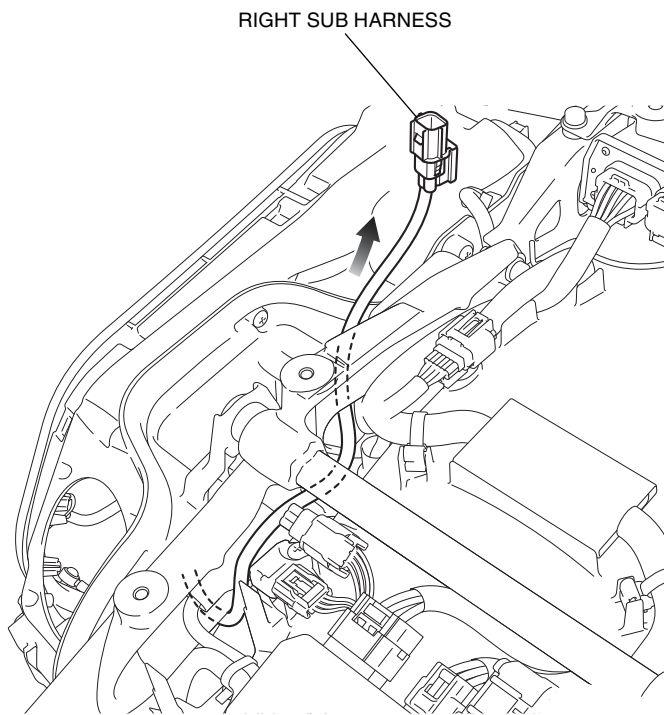

29. Install the right saddlebag in the reverse order of removal.

30. Remove the dummy connector as shown.

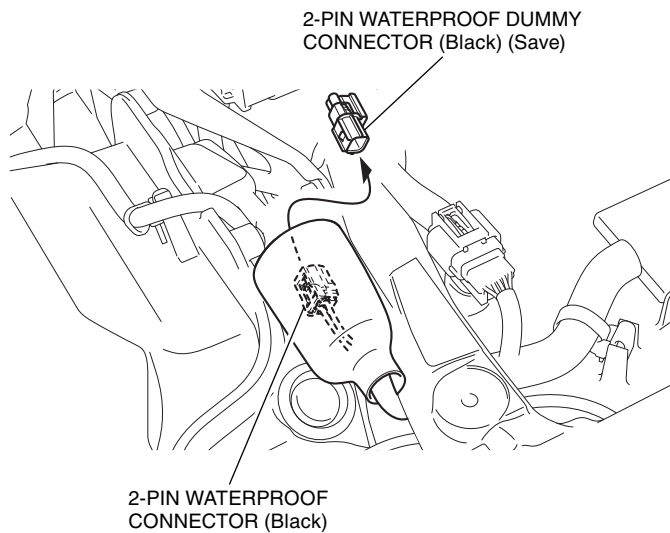

31. Connect the right sub harness as shown.

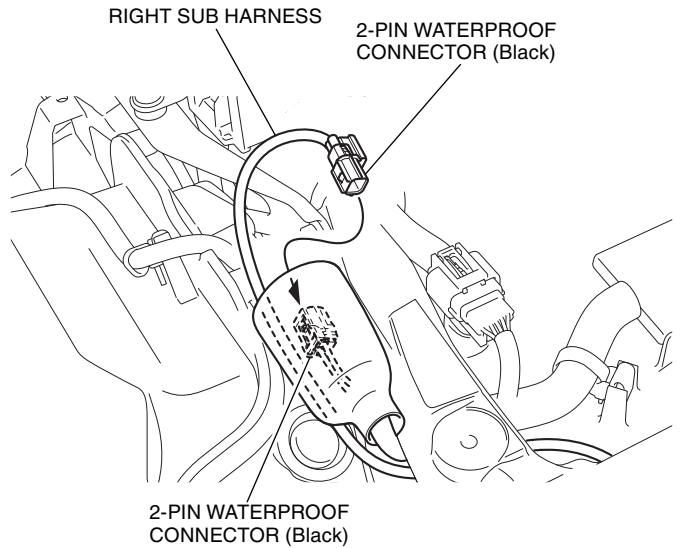

32. Secure the right sub harness with the wire ties as shown.

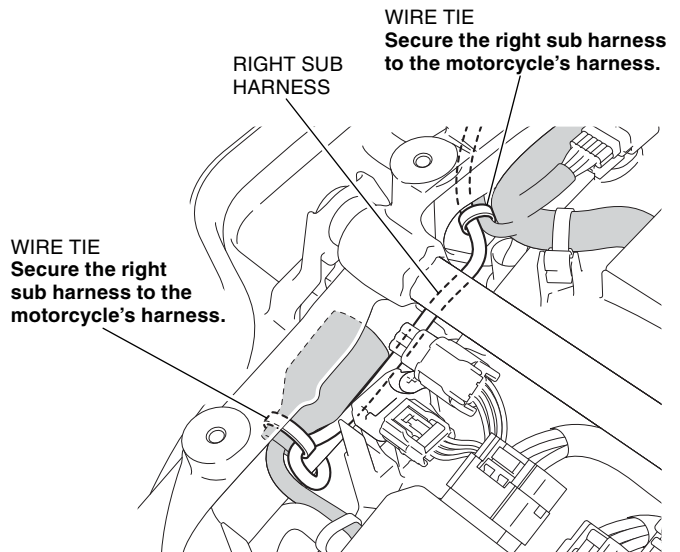

33. Route the left sub harness as shown.

<Left side>

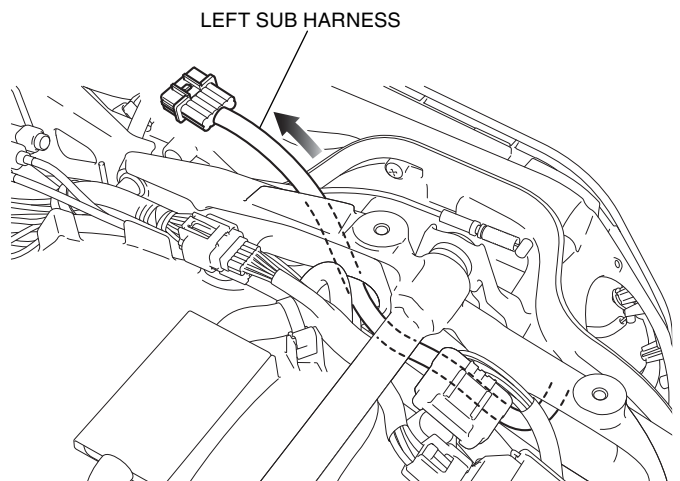

34. Install the left saddlebag in the reverse order of removal.

35. Remove the dummy connector as shown.

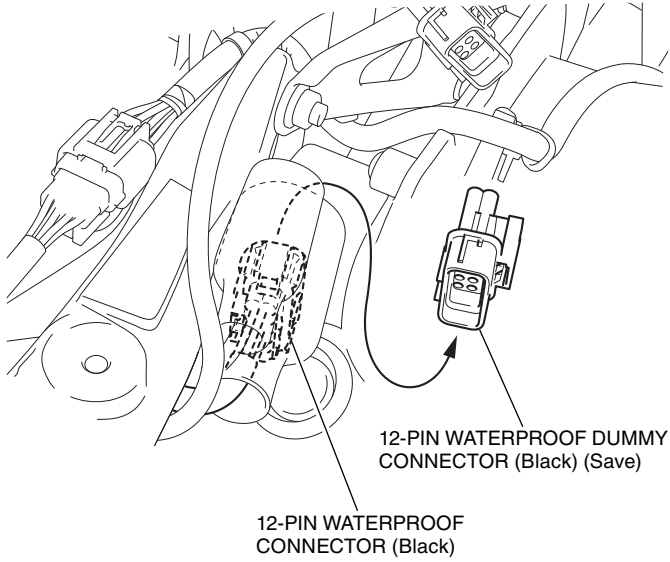

36. Connect the left sub harness as shown.

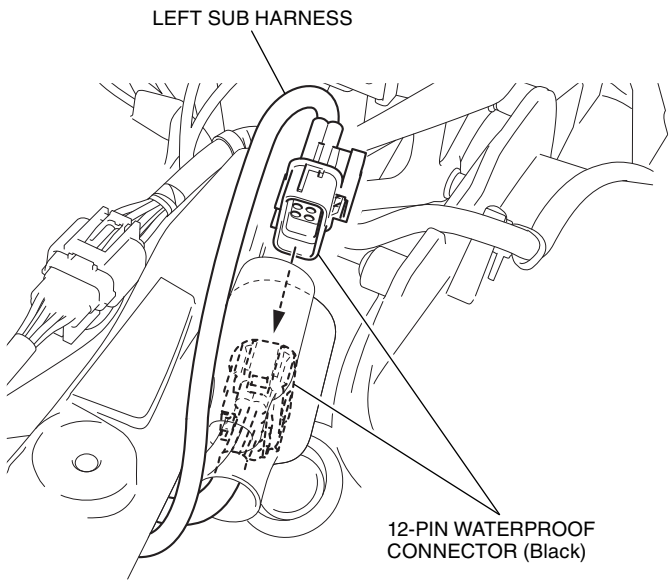

37. Secure the left sub harness with the wire tie as shown.

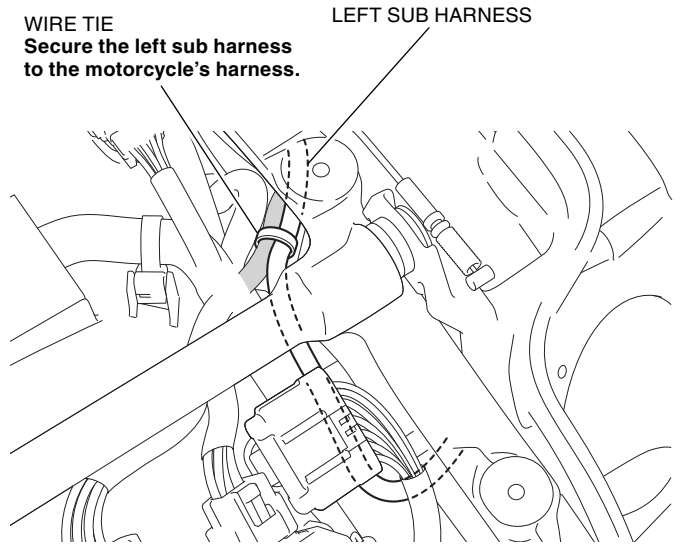

38. Install the accessory speaker as shown.

<Right side>

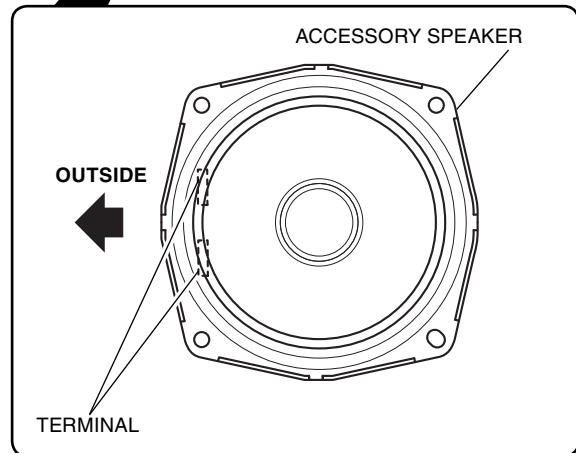
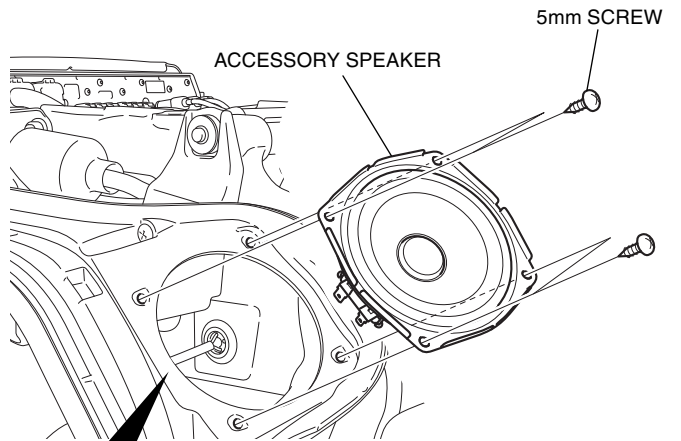

39. Connect the right sub harness as shown.

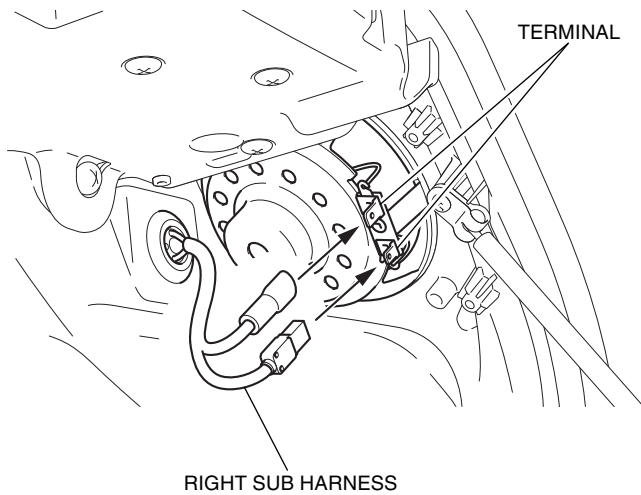

40. Install the right speaker cover as shown.

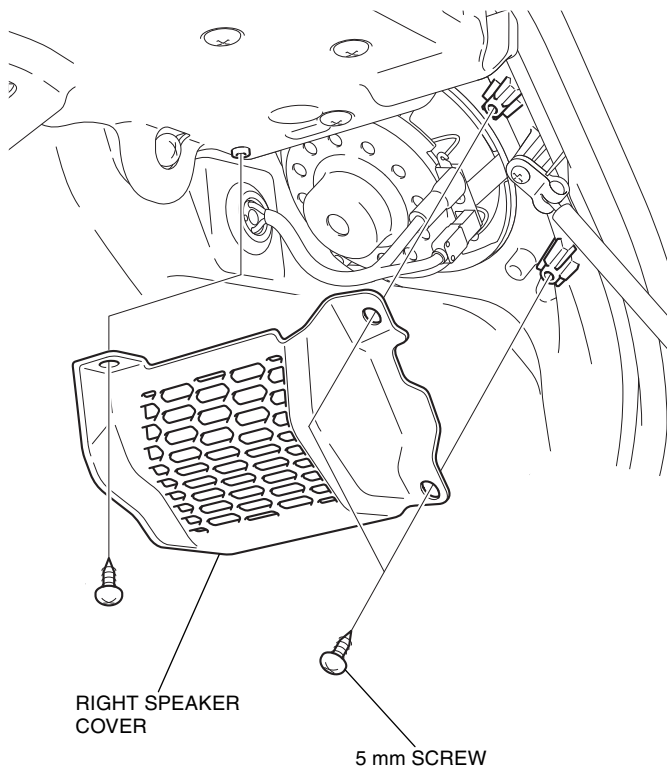

41. Install the speaker and left speaker cover in the same manner as the right side.
42. Install the motorcycle's parts in the reverse order of removal.
- **Confirm that any wire harness is not caught or too tight.**
43. Check the speaker, headlight and the other lights for proper operation.