

Digital Music Player With Bluetooth®

**For 2001-2010
Honda® GL-1800**

Part#JMDM-GL18E

Installation & Operation Instructions

Table of Contents

Product Description	Section 1	Installation Instructions	Section 4
Safety & General Information	Section 2	General Operation Instructions	Section 5
Package Contents	Section 3	Bluetooth Linking/Pairing Scenarios	Section 6

1. Product Description

This exciting new digital music player from J&M will plug directly into the CD selected music input plug on all 2001-2010 Honda Gold Wing audio systems, replacing the Honda CD changer, at a fraction of the cost.

Store and play up to 550 MP3 song tracks from your music library on a single USB Thumb drive, and toggle thru song after song using your existing handlebar audio system controls.

Plug in your remote mounted Satellite radio receiver or MP3 player, using the 3.5mm 3-conductor plug accessory cable and enjoy high-quality stereo music thru the Honda audio system CD selection.

Link by Bluetooth@your smartphone or Garmin@Zumo to the player and your smartphone stereo media or navigation commands will stream & automatically prioritize OVER whichever music files are being played from the USB Thumb drive at the time.

Control head mounts inside the tail trunk, in place of the CD changer, with direct under-seat plug-n-play harness for connection to the GL-1800 audio system.

This is a complete plug-n-play installation with pre-gummed Velcro mounting strips and installation/operation instructions..

Note: When installing this unit on 2009-2010 GL-1800s, if you wish to use the XM satellite radio feature of your audio system, with this digital music changer, you will need to purchase at additional cost J&M part# JMDM-ADT-GL18.

Supported Bluetooth Profiles

A2DP (Advanced Audio Distribution Profile)
AVRCP (Audio Video Remote Control Profile)

2. Safety and General Information

IMPORTANT INFORMATION FOR SAFE AND EFFICIENT OPERATION. READ THIS INFORMATION BEFORE USING YOUR DEVICE.

Users are not permitted to make changes or modify the device in any way. Changes or modifications not expressly approved by the party responsible for compliance could void the user's authority to operate the equipment. See 47 CFR Sec. 15.21.

This device complies with part 15 of the FCC Rules. Operation is subject to the following two conditions: (1) This device may not cause harmful interference, and (2) this device must accept any interference received, including interference that may cause undesired operation. See FCC 47 CFR Sec. 15.19 (3).

ELECTROMAGNETIC INTERFERENCE/COMPATIBILITY

Note: Nearly every electronic device is susceptible to electromagnetic interference (EMI) if inadequately shielded, designed or otherwise configured for electromagnetic compatibility.

FACILITIES: To avoid electromagnetic interference and/or compatibility conflicts, turn off your device in any facility where posted notices instruct you to do so. Hospitals or health care facilities may be using equipment that is sensitive to external RF energy.

AIRCRAFT: When instructed to do so, turn off your device when on board an aircraft. Any use of a device must be in accordance with applicable regulations per airline crew instructions.

MEDICAL DEVICES

HEARING AIDS: Some devices may interfere with some hearing aids. In the event of such interference, you may want to consult with your hearing aid manufacturer to discuss alternatives.

OTHER MEDICAL DEVICES

If you use any other personal medical device, consult the manufacturer of the device to determine if it is adequately shielded from RF energy. Your physician may be able to assist you in obtaining this information.

Industry Canada Notice to Users: Operation is subject to the following two conditions: (1) This device may not cause interference and (2) This device must accept any interference, including interference that may cause undesired operation of the device.

FCC Notice to Users: This equipment has been tested and found to comply with the limits for a Class B digital device, pursuant to part 15 of the FCC Rules. These limits are designed to provide reasonable protection against harmful interference in a residential installation. This equipment generates uses and can radiate radio frequency energy and, if not installed and used in accordance with the instructions, may cause harmful interference to radio communications. However, there is no guarantee that interference will not occur in a particular installation. If this equipment does cause harmful interference to radio or television reception, which can be determined by turning the equipment off and on, the user is encouraged to try to correct the interference by one or more of the following measures:

- Reorient or relocate the receiving antenna.
- Increase the separation between the equipment and the receiver.
- Connect the equipment to an outlet on a circuit different from that to which the receiver is connected.
- Consult the dealer or an experienced radio/TV technician for help.

3. Package Contents

- Digital music player w/ GL-1800 connection harness
- Auxiliary extension cable
- Velcro strips for mounting

4. Installation Instructions

Integration component terminal Installation and connections

Diagram A and B

1. Remove:
Seat

2. Locate the mark on the lower left edge of the tour pack and drill a 1 1/4" hole. **Diagram A**

3. Route the included cables through the hole and install the supplied rubber grommet on the cable and into the 1 1/4" hole.

4. Locate the white 14 pin plug located in the black rubber boot next to the cross-member and relay box under the seat. **Diagram B**

5. Plug the white 14 pin connector from the JMDM-GL18E harness into the corresponding plug on the bike. **NOTE:** The cable must be routed under the frame cross member to prevent damage to the cable.

6. If you wish to use the aux input function, route the included Auxiliary cable to your handlebar mounted satellite radio/MP3 player or other desired mounting location. Note: Connection of the Auxiliary cable to the JMDM-GL18E will override the USB Thumb drive and music from the USB Thumb drive will not be heard until the aux cable is unplugged at the main unit.

7. Test the JMDM-GL18E by inserting a USB Thumb drive or AUX input device. Turn the ignition switch to either the On or ACC position and select CD on the stereo.

Using the "Tune/Disc" up down toggle control on the handlebar, select between individual tracks with each single toggle, or hold up/down for 3 seconds to change to a different folder/CD #.

Important Note: When installing this unit on 2009-2010 GL-1800s, if you wish to use the factory installed XM satellite radio feature of your audio system, in conjunction with the J&M digital music player, you will need to purchase at an additional cost J&M part# JMDM-ADT-GL18.

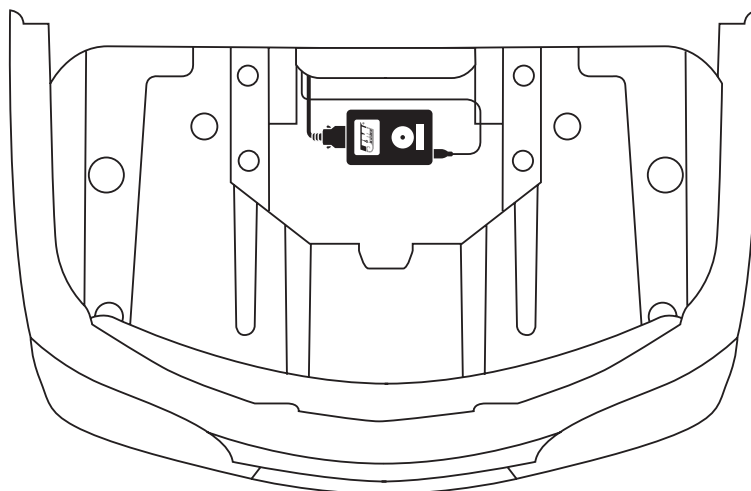
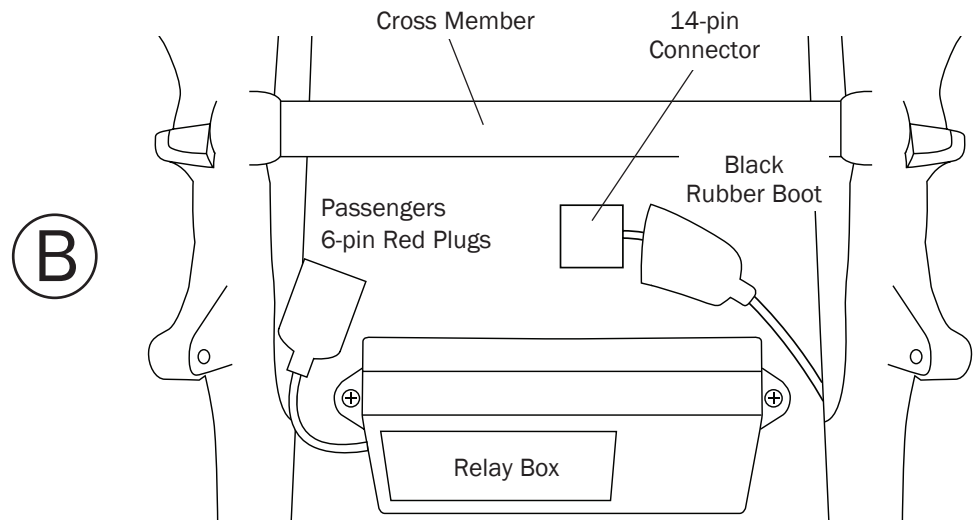
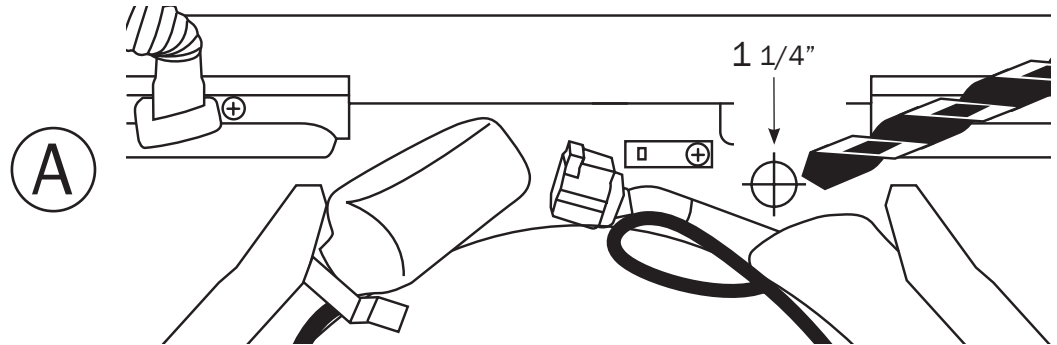

5. General Operation Instructions

General Tips for Use with Aux Input

When the Auxiliary audio cable is plugged into the JMDM-GL18E the music from the USB Thumb drive will no longer be heard. Plug the auxiliary cable into the satellite radio/MP3 player. The "Tune/Disc" handlebar lever will have no effect on functions of the satellite radio/MP3 player.

General Tips for Use with USB Thumb Drive

1. Plug your USB Thumb Drive into the computer.
2. Click on **Start** and then **Computer**.



3. Now find the USB thumb-drive (designated as Disk (F): in this example)

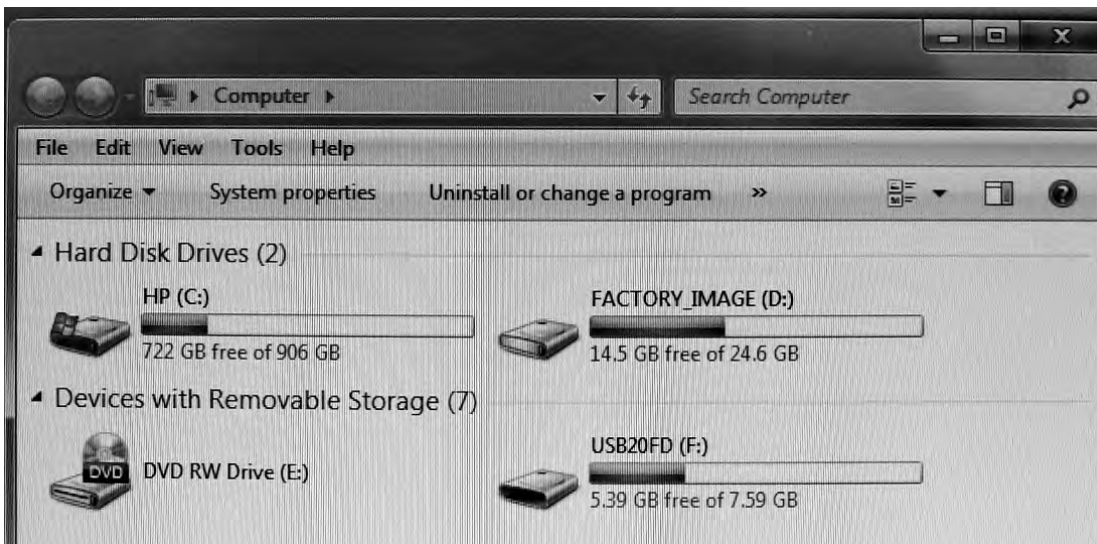

4. Click on the **Removable Disk (F):** and you should now have an open folder, this is also known as the Root Folder.

5. At this point Music can be added to the USB Thumb-Drive. You will need to locate your MP3, WMA or WAV files on your computer.

6. To transfer music files from your computer to the USB Thumb-Drive, drag and drop at least one track (up to 95) into this main root folder. This main root folder must contain at least one MP3, WMA or WAV file/track or the JMDM-GL18E will not play. This main root folder will be displayed on the Honda radio display as CD1.

Additional folders can now be added to the root folder by clicking on **(Top-Left) File**, then **New**, then **Folder**.

For the 2001-2010 GL-1800, it works best to limit the # of folders to 5, plus the root, with no more than 95 files/tracks per folder. The suggested file format for music is MP3, while WMA & .WAV can be used if the files/tracks are not copy-protected. If you are using iTunes, the music files will need to be converted to MP3 before they are loaded into the USB thumb drive.

Here is an example of five folders with 39 music files/tracks in the main root folder.



7. When you are finished loading the USB thumb-drive, unplug it from the computer, insert into the JMDM-GL18E and select CD on the Honda audio system control panel.

The music will begin to play and is displayed as CD1 and you can track up/down within the CD1 root folder, by using the handlebar control. To change to the next folder press and hold the "Tune/Disc" up toggle for three seconds and CD2 will begin to play. If you do not press and hold the "Tune/Disc" up/down toggle for the three seconds, the next track will play in CD1 instead of the CD2 folder.

6. Bluetooth Linking/Pairing Scenarios

Note: CD must be selected on the Honda GL-1800 audio system for the following to function properly.

Pairing and Operation of the JMDM-GL18E to a Bluetooth Enabled Music/Media Device.

1. Turn the motorcycle ignition switch to on or accessory position.
2. Go into the settings menu of the Smartphone/Music/Media device to be paired and select "search for new Bluetooth device".
3. Once JM-MPBT-3 is displayed on your screen, click on it. When you are asked for a passkey, enter: 9088.
4. Once the music/media player connects to the JMDM-GL18E the music will be heard through the Honda GL-1800 audio system and the music from the USB Thumb drive will pause.
5. Volume adjustments can be made on the music/media player itself, along with the handlebar volume controls on the GL1-1800
6. Once paired the Bluetooth music/media player will automatically re-pair each time the ignition switch is turned on.

Pairing and Operation of the JMDM-GL18E to a Bluetooth Enabled Garmin Zumo 660/665

1. Turn the motorcycle ignition switch to on or accessory position.
2. Select the hands-free menu on the Zumo command center, go into the Bluetooth section and have it search for devices. When JM-MPBT-3 is displayed on the screen, click on it. When you are asked for a passkey, enter: 9088. Your Zumo unit should now pair with the JMDM-IPBT-GL18.
3. If your Zumo has a built in media player, you can play music through the GI-1800 audio system. Select the media player and click on the play button. Adjust the music volume to a maximum level before distortion. The Tune/Disc button the handlebar can be used to track the music up and down on the Zumo 660/665.
4. To set the Zumo navigation volume levels, refer to the operation instructions included with your Zumo 660/665.
5. Once paired the Zumo will not need to be re-paired to the JMDM-GL18E each time the ignition switch is turned on.

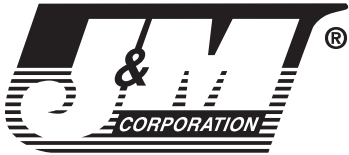

J&M Corporation
Tucson, Arizona, U.S.A.
Tel. 1-800-358-0881
www.jmcorp.com
audio@jmcorp.com

Thank you for the confidence you have shown in J & M by purchasing one of our innovative products. It will give you many hours of riding pleasure. If you have any questions during installation or require more information about this product, you may call our Customer service Department (English only, please) at 1-800-358-0881, Monday through Friday, 8:00 a.m. to 5:00 p.m. Mountain Standard Time, U.S.A.



WARRANTY REGISTRATION FORM Please fill out this card completely and mail it immediately after purchase. Please be sure that your zip code and serial number (if applicable) are legible. This will help us to serve you better. **NOTE: Lift the velcro flap on the right speaker pouch to expose serial number.**

(PLEASE PRINT)

Name _____

Address _____

City _____ State _____ Zip _____

Motorcycle Other E-mail _____

Make _____ Model _____ Year _____

Product part number _____

Serial number (if applicable) _____

Date of purchase _____

Name of dealer it was purchased from _____



Mail to:
J&M Corporation
1415 S. Cherry Avenue
Tucson, AZ 85713
U.S.A.

WARRANTY AND REPAIR INFORMATION

TWO YEAR LIMITED WARRANTY In order to facilitate the servicing of this warranty, the Warranty Registration Form should be filled out and returned within 10 days of the date of purchase. However, return of the Warranty Registration Form is not a precondition of this warranty, and this Warranty will be observed by **J&M CORPORATION** whether or not the Warranty Registration Form is returned, on the condition that other satisfactory evidence of the date of the original purchase is provided to **J&M CORPORATION**.

WHO PROVIDES THE WARRANTY? This warranty is provided by **J&M CORPORATION**.

WHO IS PROTECTED? This warranty is extended only to the original owner of this J&M CORPORATION product and may not be transferred or assigned.

WHAT IS COVERED AND HOW LONG? This warranty covers all defects in material or workmanship of our product for a period of 2 years from date of original retail purchase. At its option, **J&M CORPORATION** will repair or replace any defective part(s) or equipment.

The provisions of the warranty shall not apply to any unit which has been subjected to misuse, neglect, incorrect mechanical or electrical installation, unauthorized modifications, accident, nor to units which have been repaired or altered outside of our factory.

PROCEDURE FOR OBTAINING PERFORMANCE OF WARRANTY In the event that the product does not conform to this warranty, the product should be shipped prepaid to the **J&M CORPORATION** service facility. Transportation charges, insurance fees, and labor costs for shipment, removal, or reinstallation of our product are not covered by this warranty. Loss or damage in shipment is the sole responsibility of the freight carrier.

FOR YOUR INFORMATION Repair as provided under this warranty is the exclusive remedy of the consumer. **J&M CORPORATION** shall not be liable for any incidental or consequential damages or for breach of any express or implied warranty on this product. Except to the extent prohibited by applicable law, any implied warranty of merchantability or fitness for a particular purpose on this product is limited in duration to the duration of the warranty. Some states do not allow the exclusion or limitation of incidental or consequential damages, or allow limitations on how long an implied warranty lasts, so the above limitations or exclusion may not apply to you. This warranty gives you specific legal rights which vary from state to state.

J&M CORPORATION reserves the right to make changes in design and to make improvements in its products without the obligation to incorporate the changes or improvements in any of its previously manufactured products.

J&M CORPORATION has not authorized anyone to make representations or warranties other than the warranty contained herein.

The above warranty is effective for all products manufactured after 10/01/86.

NON-WARRANTY REPAIR RATES **J&M CORPORATION** reserves the right to change the labor repair rates without prior notice. At the time of this printing the out-of-warranty repair is \$40 per hour for labor only. However, the customer is advised to verify the current rate when he/she calls customer service to obtain the return authorization number.

FACTORY SERVICE ADDRESS J&M Corporation, 1415 S. Cherry Avenue, Tucson, Arizona, 85713, U.S.A. Tel: 1-800-358-0881 audio@jmcorp.com www.jmcorp.com

CUSTOMER SERVICE NUMBER 1-800-358-0881

Please complete
WARRANTY REGISTRATION FORM
on the reverse side and send to J&M Corporation